



ICMGP 2024
CAPE TOWN • SOUTH AFRICA • 21 - 26 JULY
CAPE TOWN INTERNATIONAL CONVENTION CENTRE

Genetic determinisms involved in mercury resistance mechanism in a sulfate reducing bacterium: impact on mercury accumulation and methylation



Sophie BARROUILHET, Mathilde MONPERRUS, Claire GASSIE, Maureen LE BARS, Alain DOLLA, Bahia KHALFAOUI-HASSANI, Rémy GUYONEAUD, Marie-Pierre ISAURE, Marisol GOÑI URRIZA.



Introduction

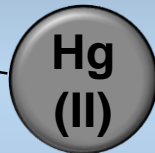

Methylation

Methylmercury

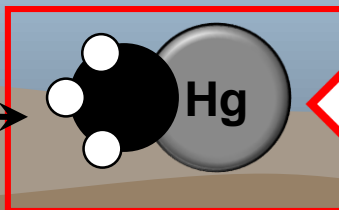

Minamata disease

Oxic environments

Anoxic environments



Introduction

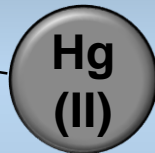

Methylation

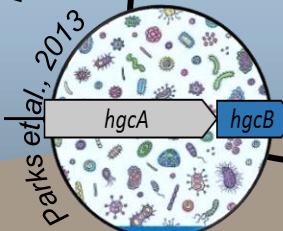

Methylmercury

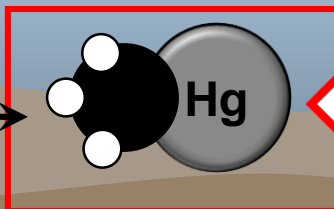

Oxic environments

Anoxic environments

Anaerobic microorganisms
(like Sulfate reducing bacteria)



Minamata disease



Introduction



Oxic environments

Anoxic environments

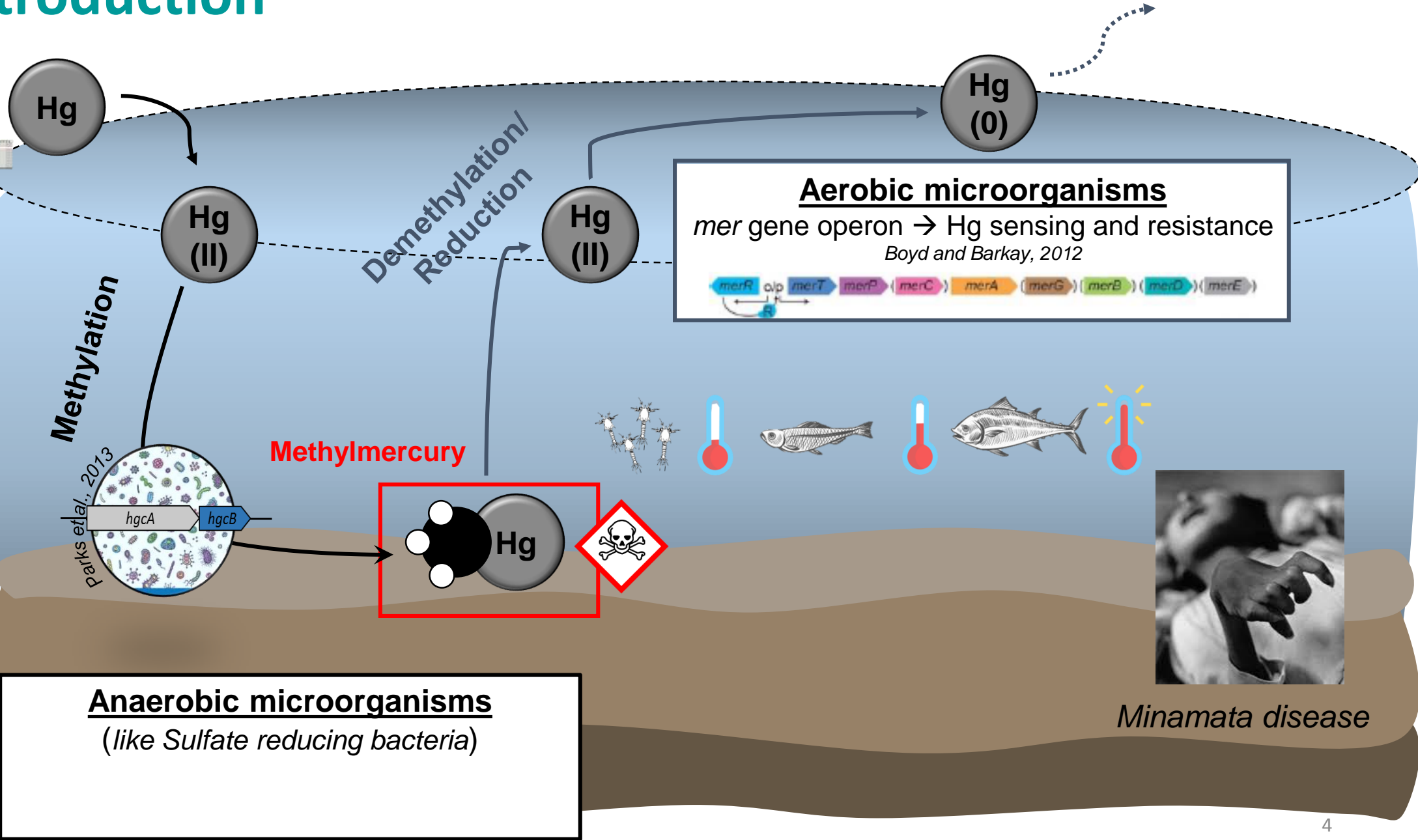

Minamata disease



Introduction



Oxic environments
Anoxic environments

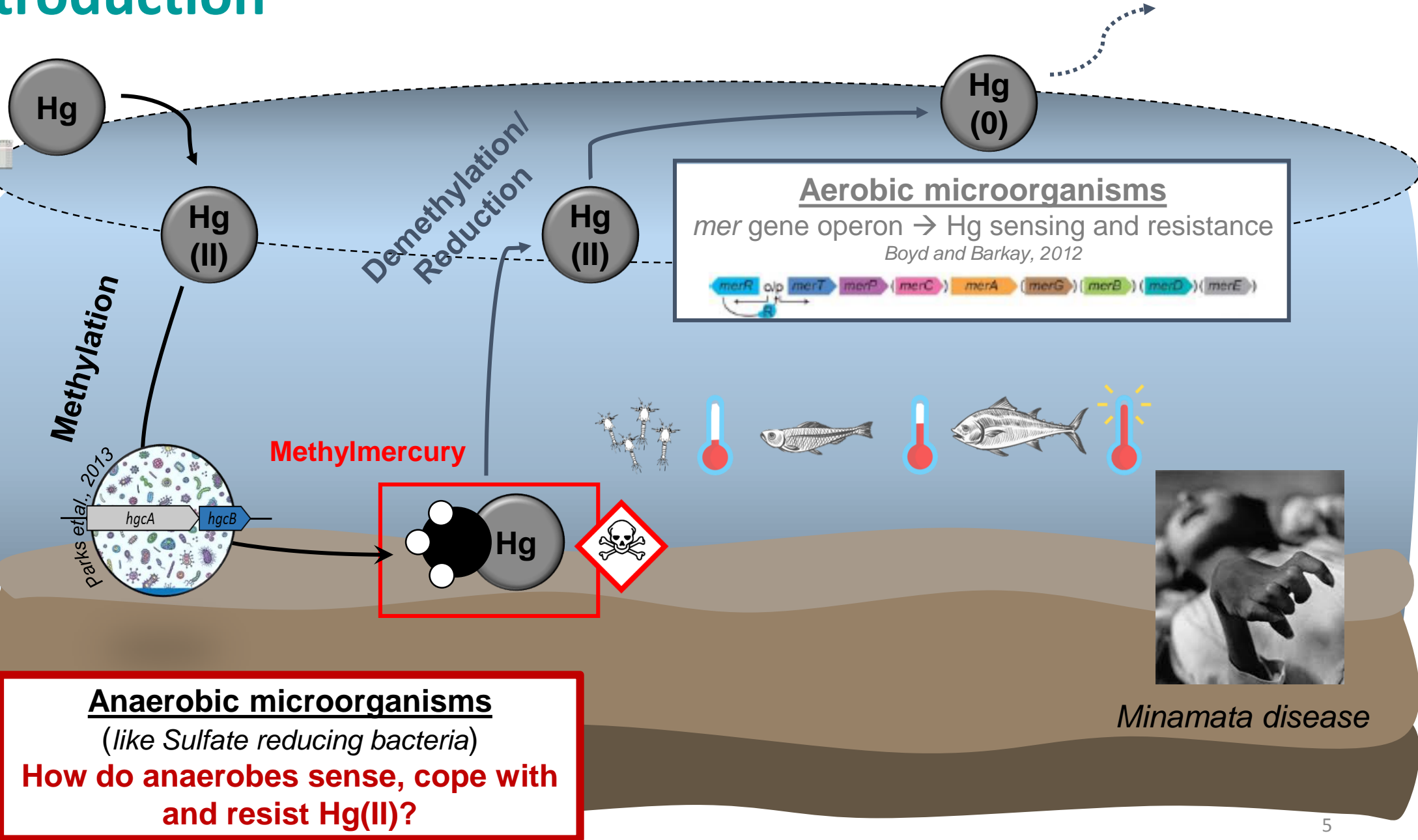

Minamata disease



Introduction

Differential transcriptomic study

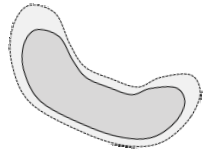
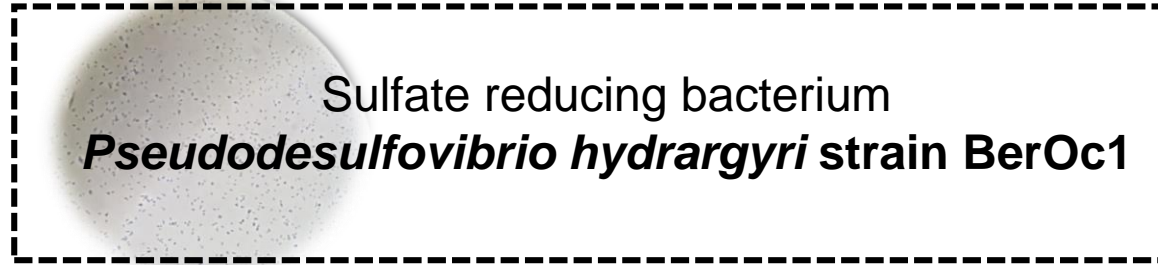

Without Hg

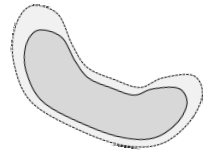

+ Hg(II)



Genes overexpressed?



Introduction

Differential transcriptomic study

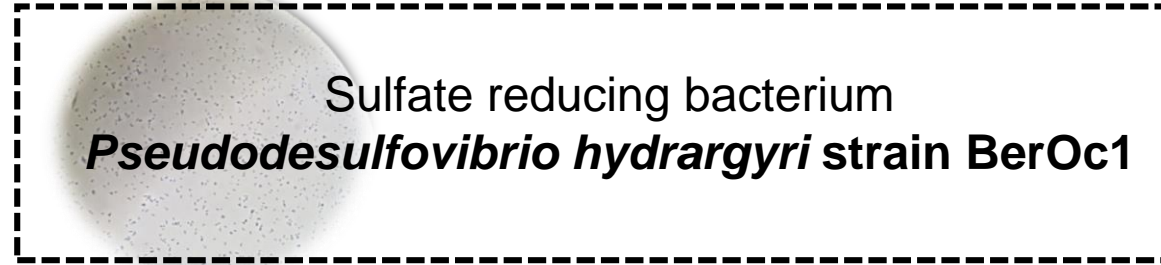

Without Hg

+ Hg(II)

Genes overexpressed?

→ Cluster of 4 genes overexpressed

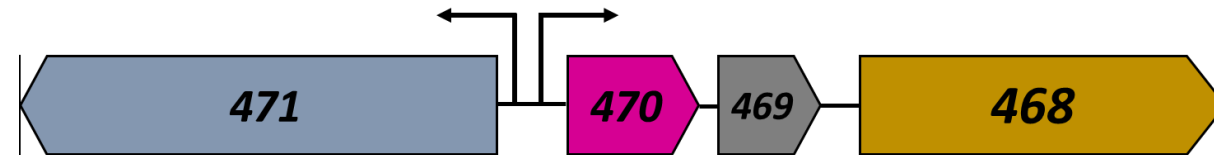



Introduction

Differential transcriptomic study

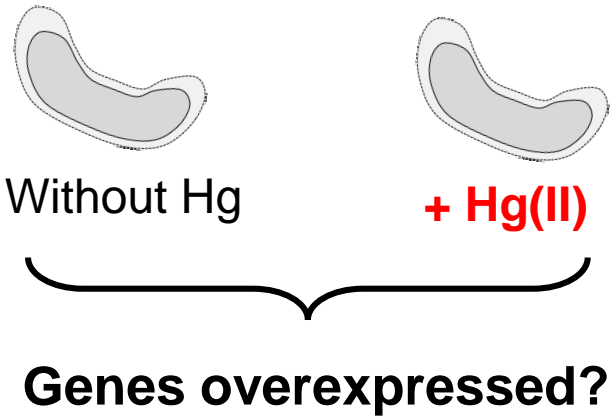
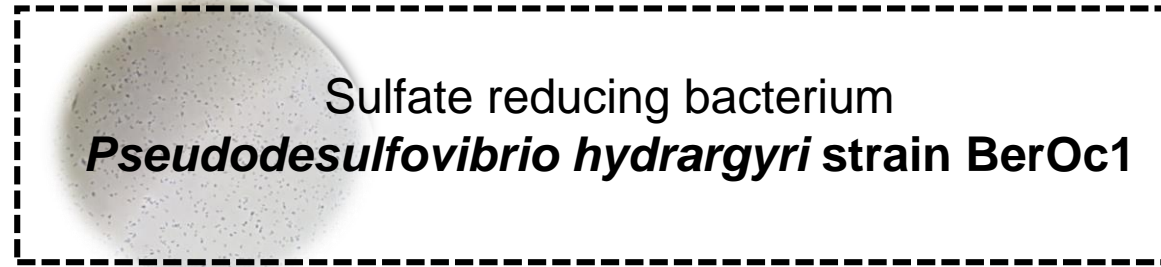

→ Cluster of 4 genes overexpressed

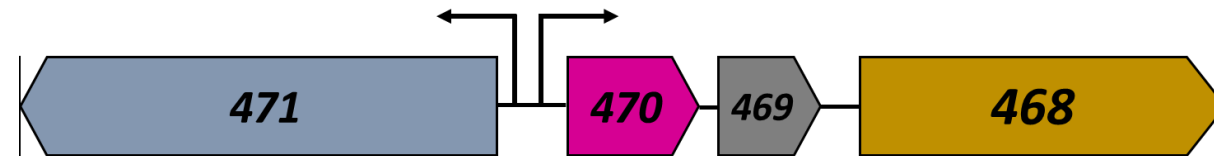

Homologies with metal resistant systems



Introduction

Differential transcriptomic study

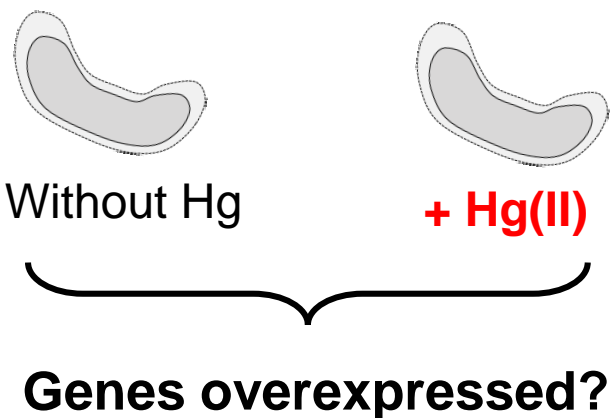
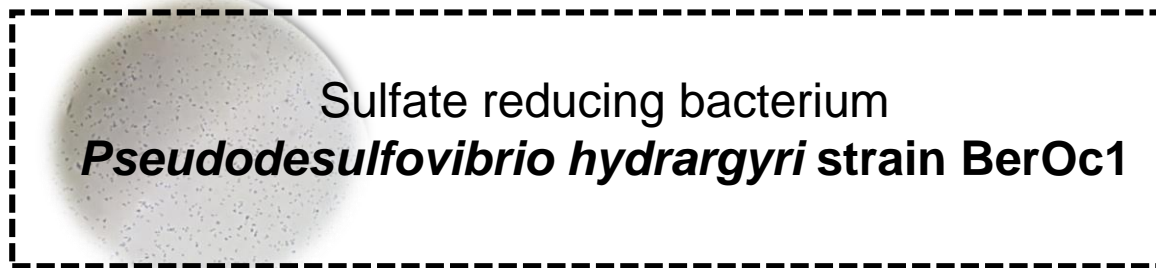

→ Cluster of 4 genes overexpressed

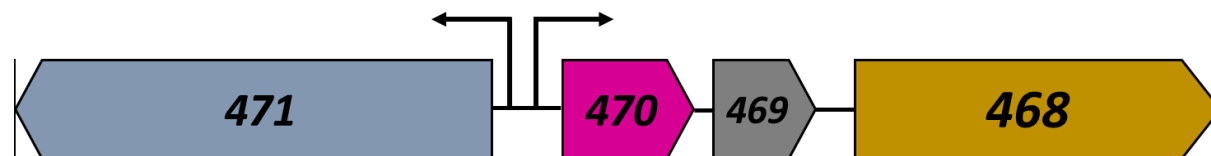

Homologies with metal resistant systems

Objective

Decipher the role of these genes to better understand the fate of mercury in anoxic environments and, the impact on methylmercury spread



Strategy

1

Gene expression analysis

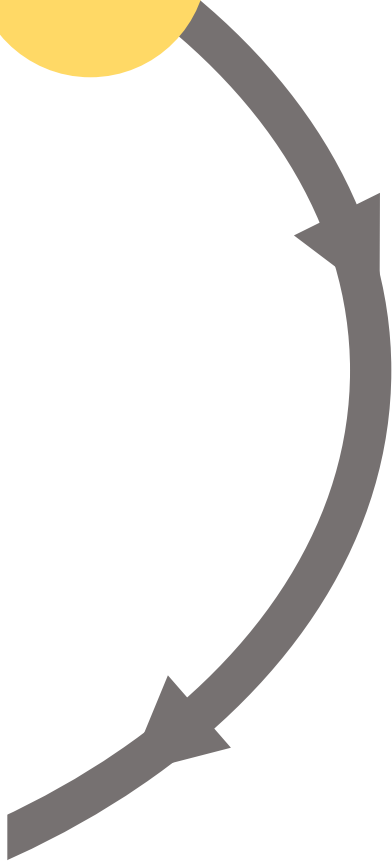
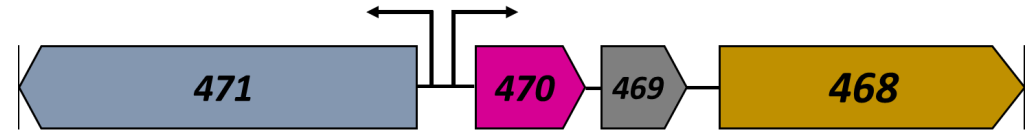



Strategy

1

Gene expression analysis

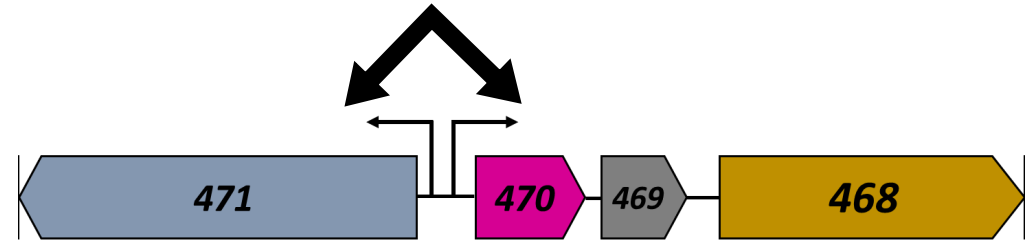

- Induction by Hg(II) (Transcriptional fusion)
- Co transcription (RT PCR)

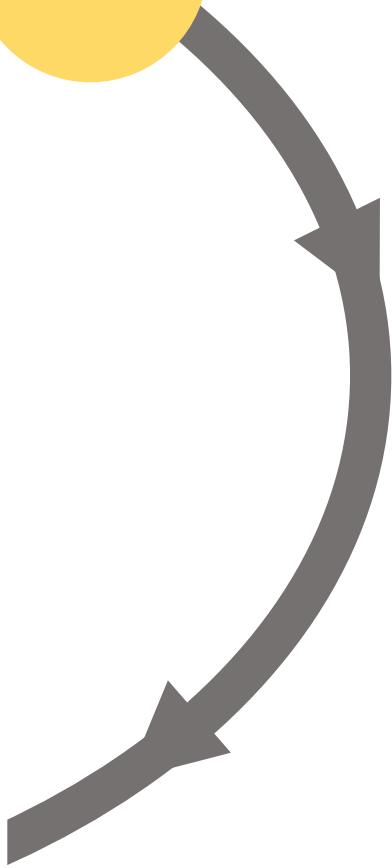



Strategy

1

Gene expression analysis

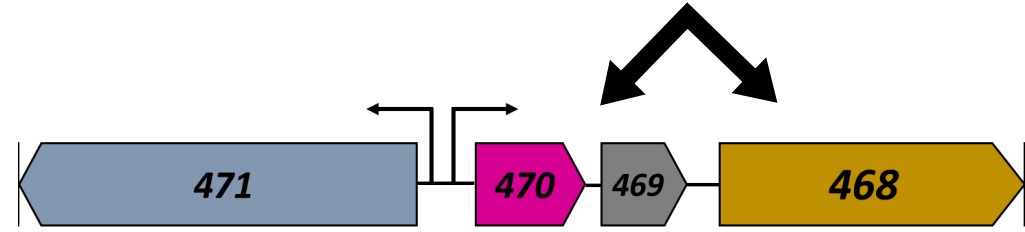

- Induction by Hg(II) (Transcriptional fusion)
- Co transcription (RT PCR)

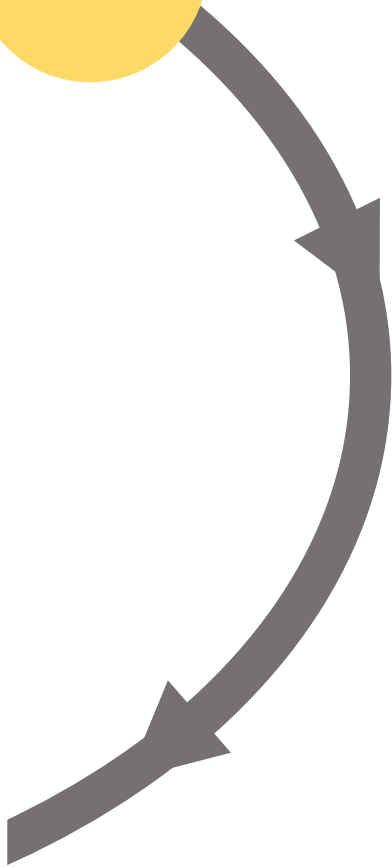



Strategy

1

Gene expression analysis

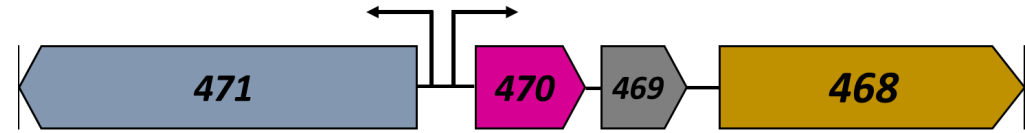

- Induction by Hg(II) (Transcriptional fusion)
- Co transcription (RT PCR)

2

Generation of deleted mutant strains



Strategy

1

Gene expression analysis

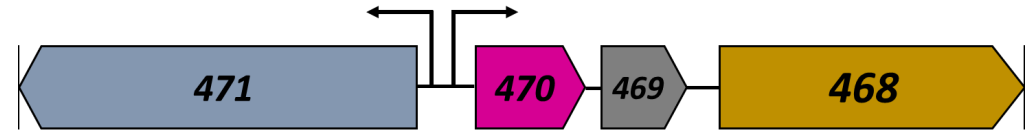

- Induction by Hg(II) (Transcriptional fusion)
- Co transcription (RT PCR)

2

Generation of deleted mutant strains

3

Hg phenotype analysis



Results

1

Gene expression analysis (Induction by Hg(II))

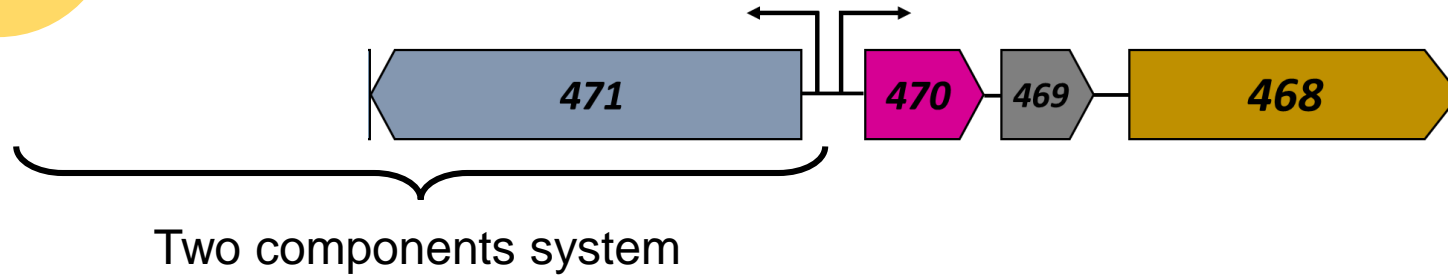



Results

1

Gene expression analysis (Induction by Hg(II))

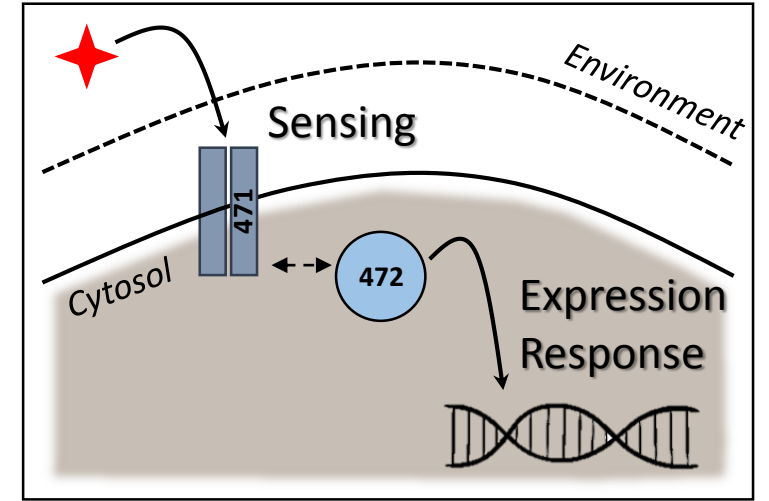
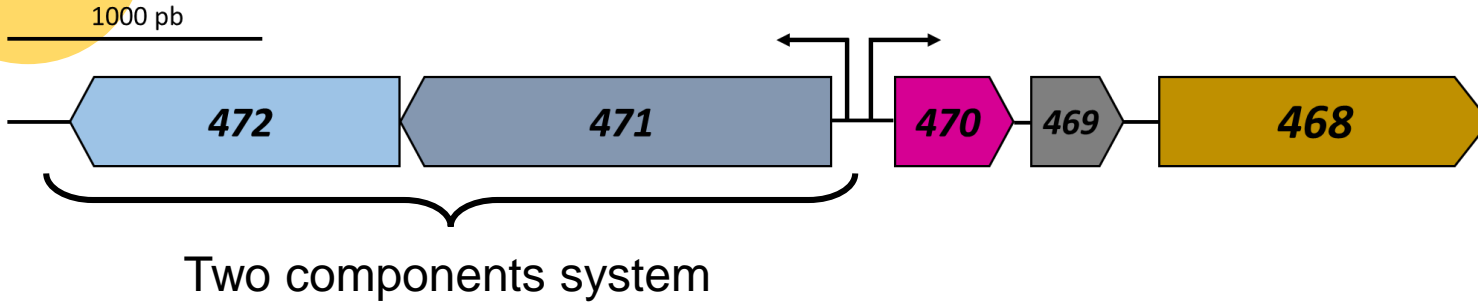



Results

1

Gene expression analysis (Induction by Hg(II))

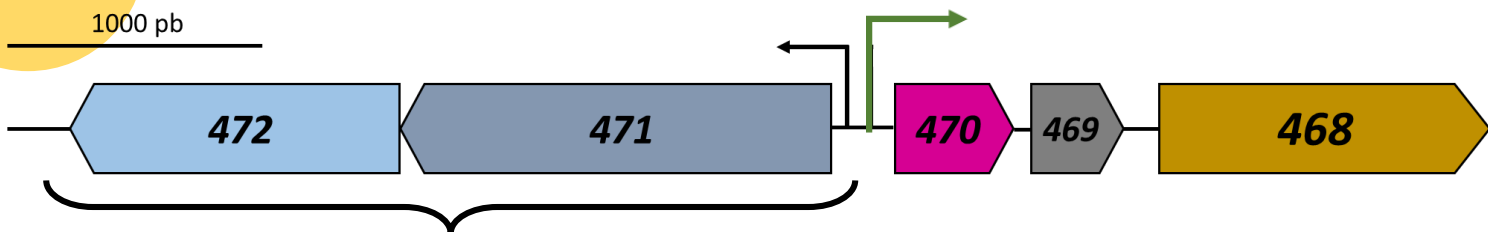

Two components system

Response only

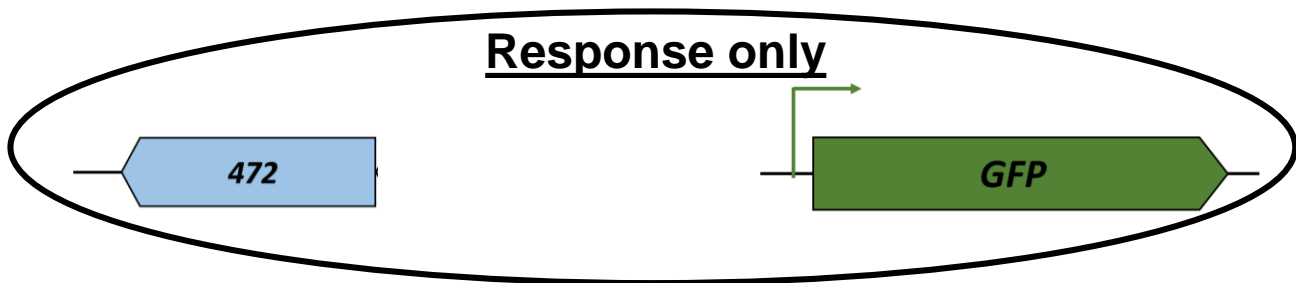

Response + Sensing

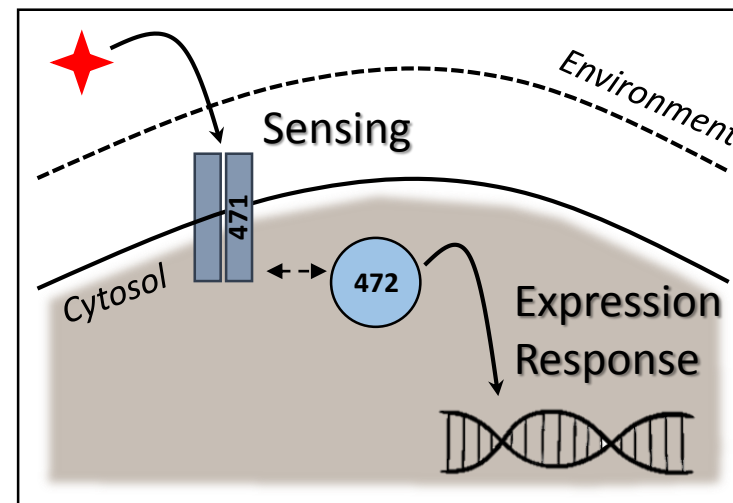
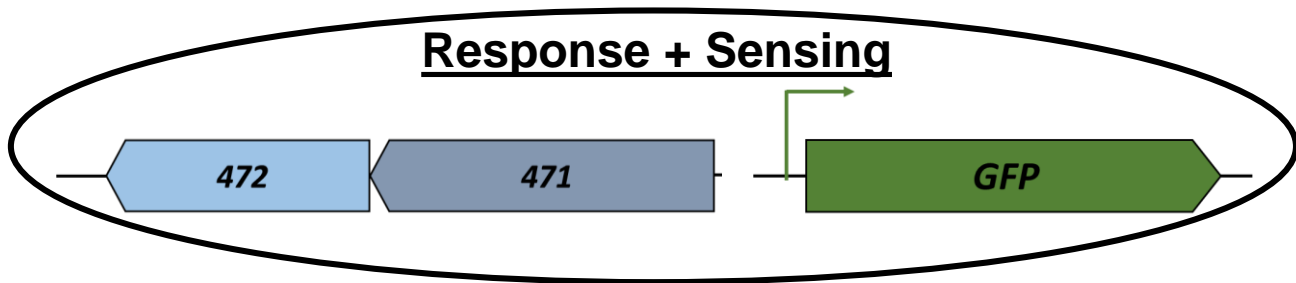



Results

1

Gene expression analysis (Induction by Hg(II))

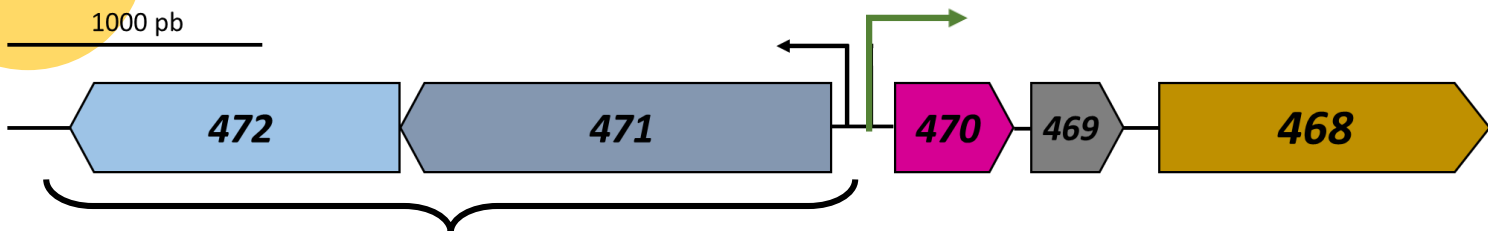

Two components system

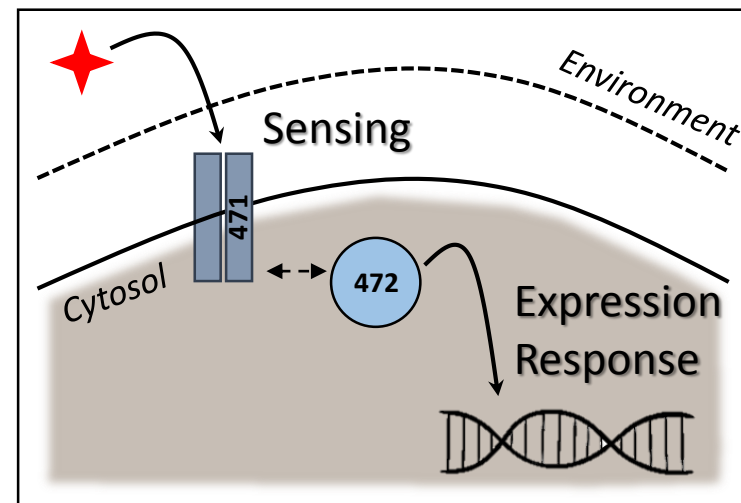

Response only

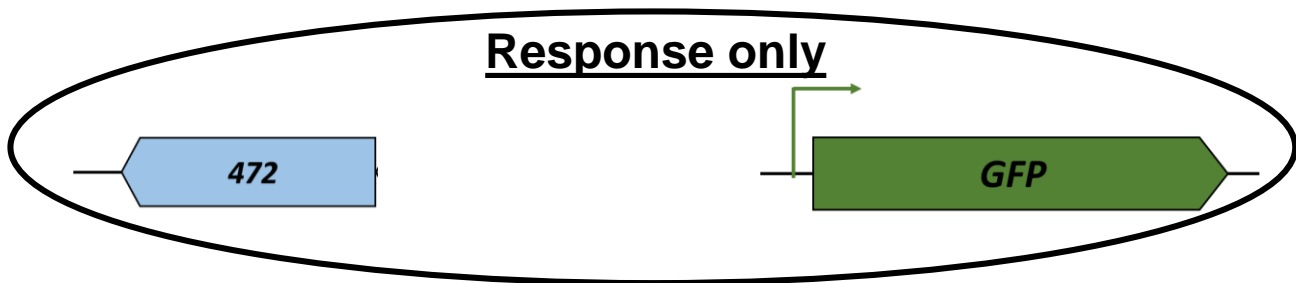

Response + Sensing

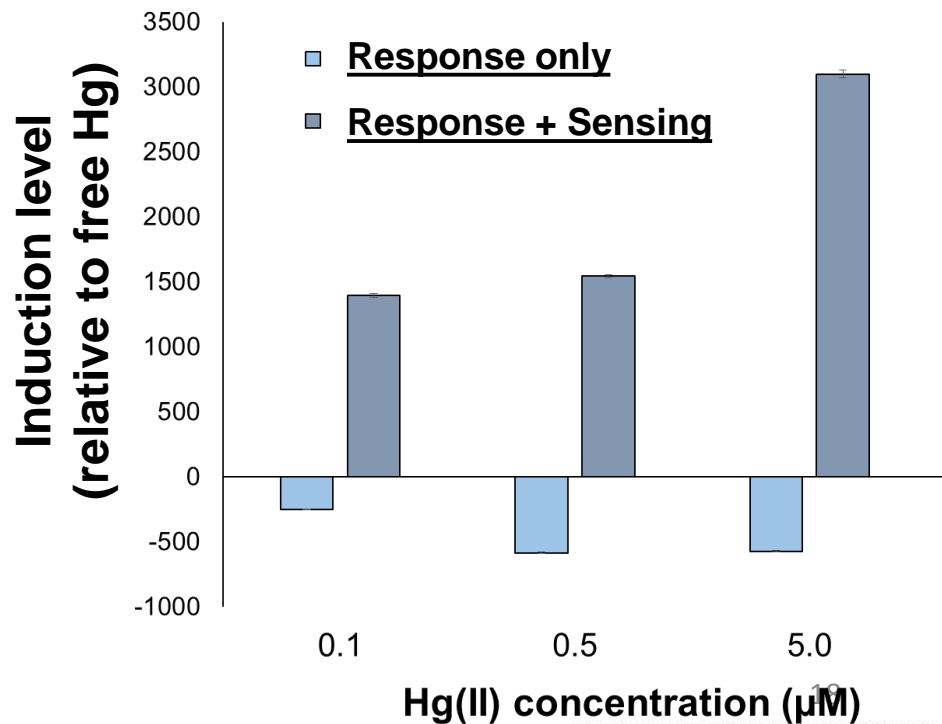
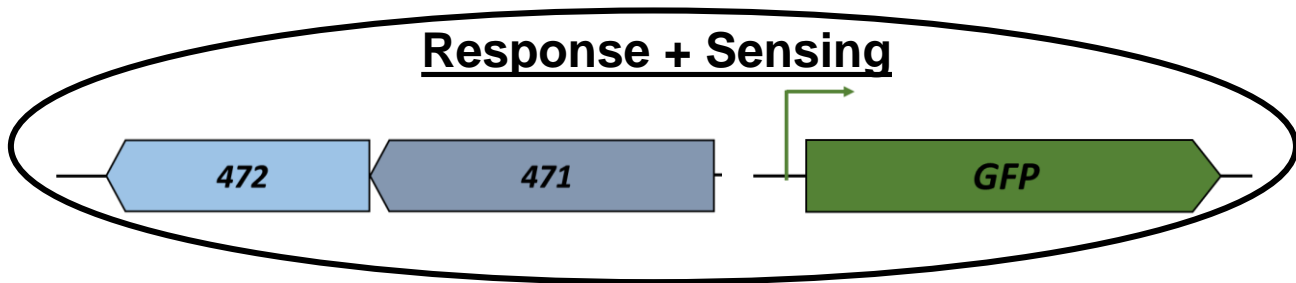



Results

1

Gene expression analysis (Induction by Hg(II))

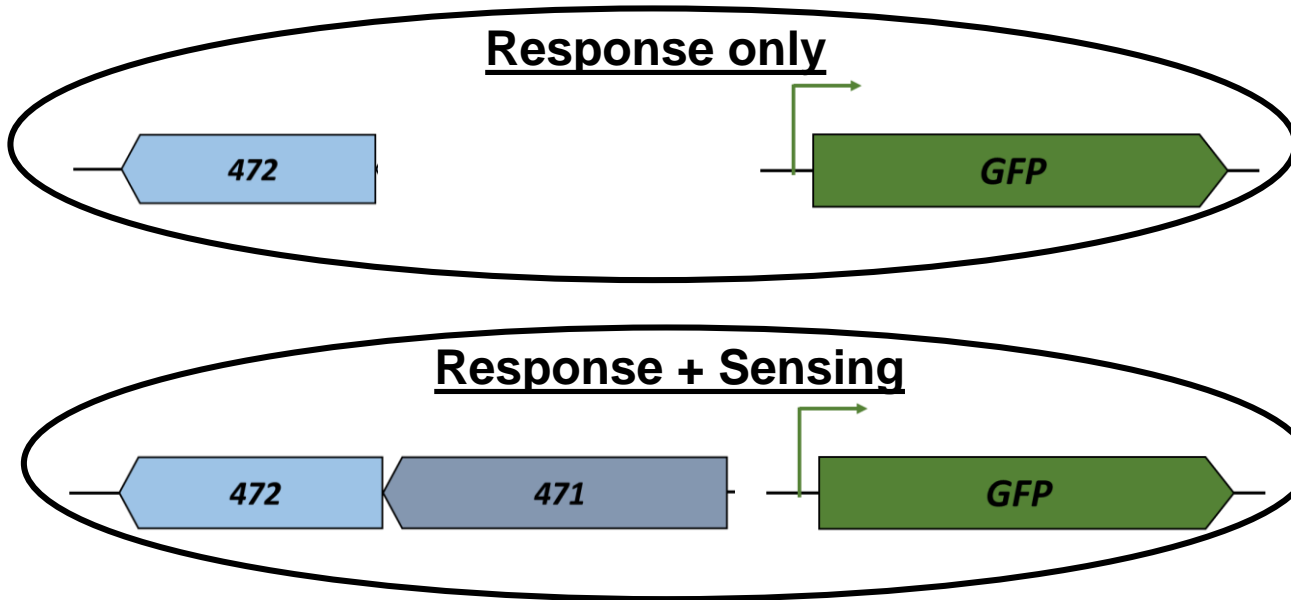
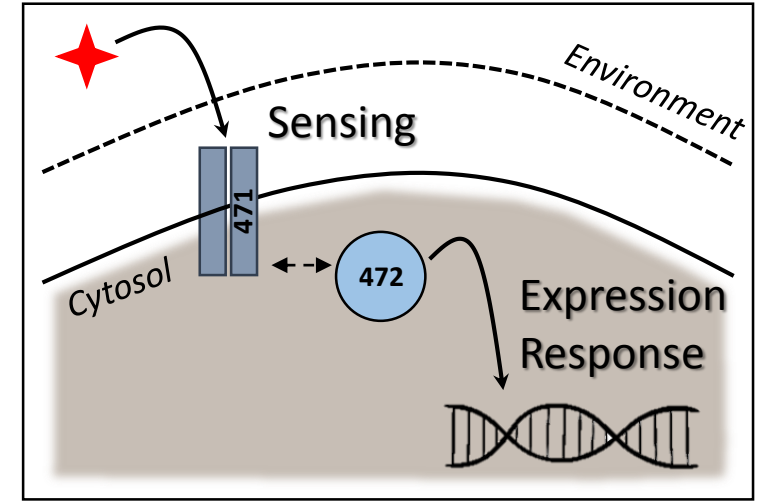
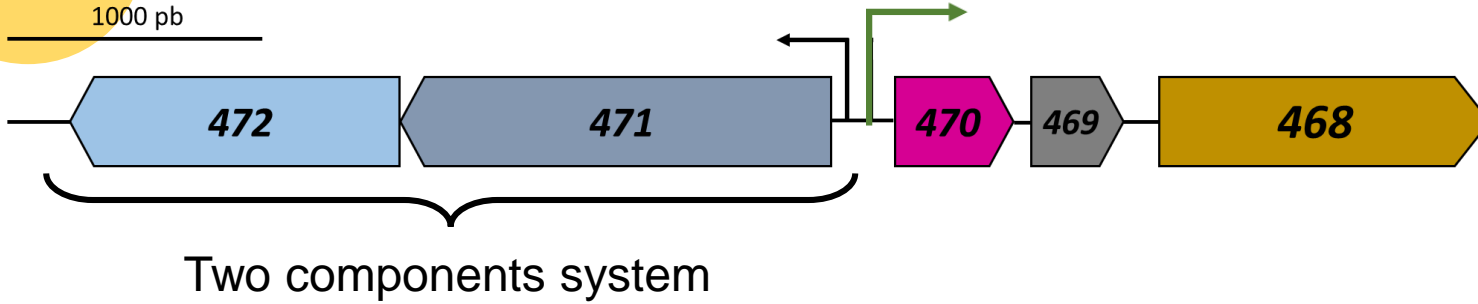

Induction level
(relative to free Hg)

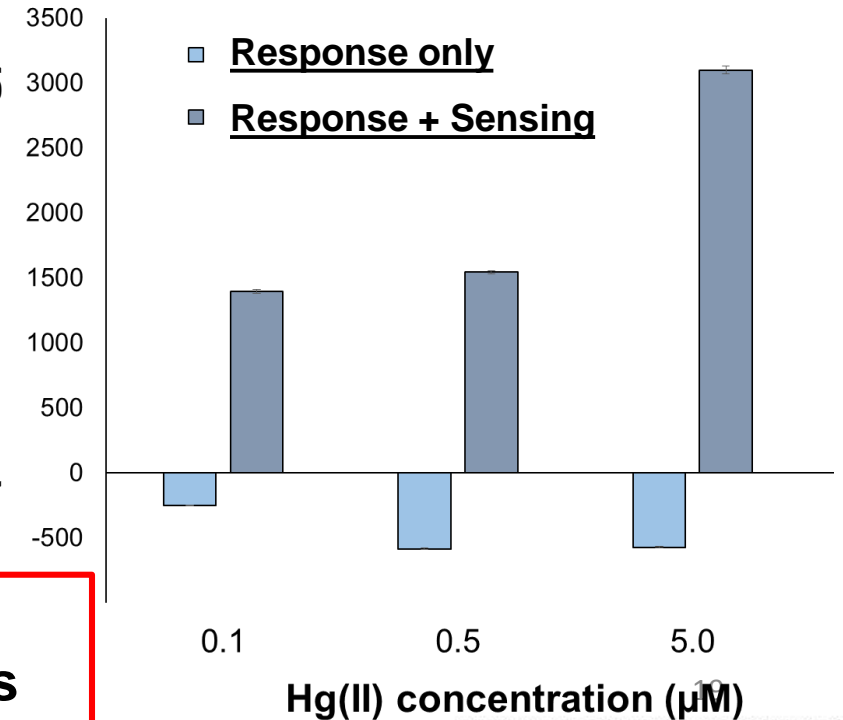

- 471 is necessary to sense Hg(II)
- Cluster 471-472 transduced Hg(II) response to forward genes



Results

1

Gene expression analysis (Co transcription)

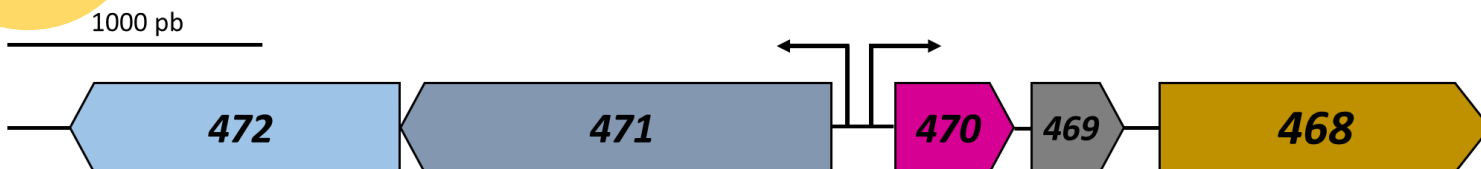



Results

1

Gene expression analysis (Co transcription)

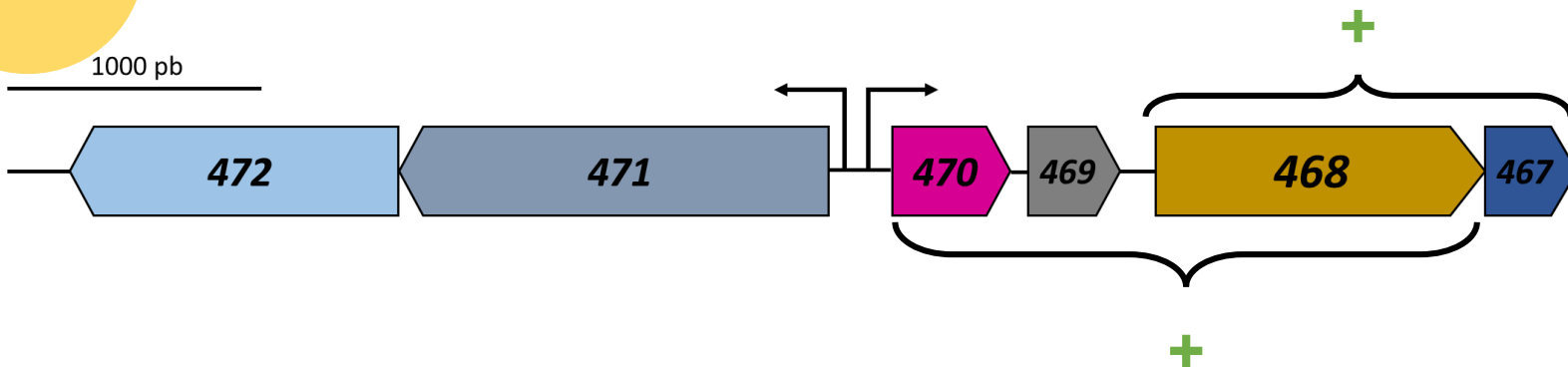



Results

1

Gene expression analysis (Co transcription)

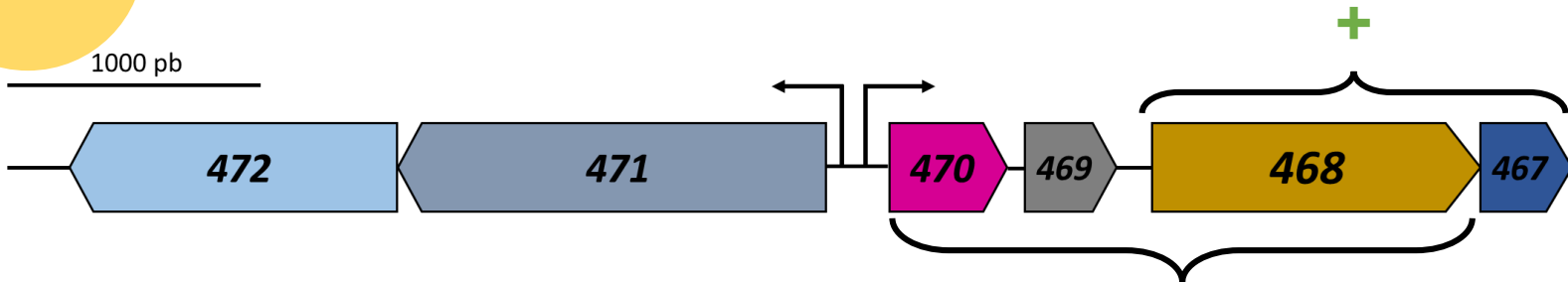

2

Generation of deleted mutant strains

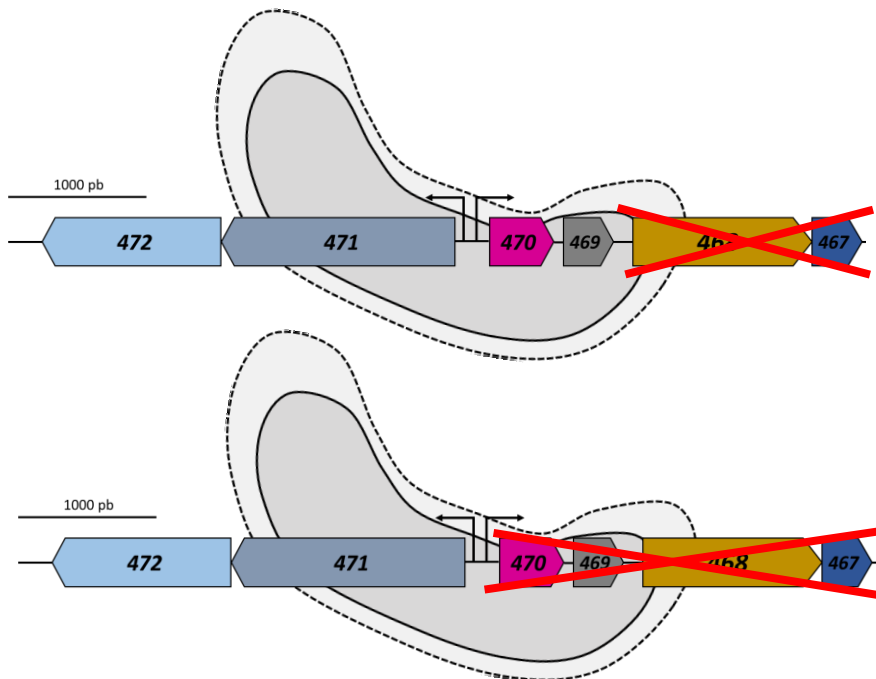

VS

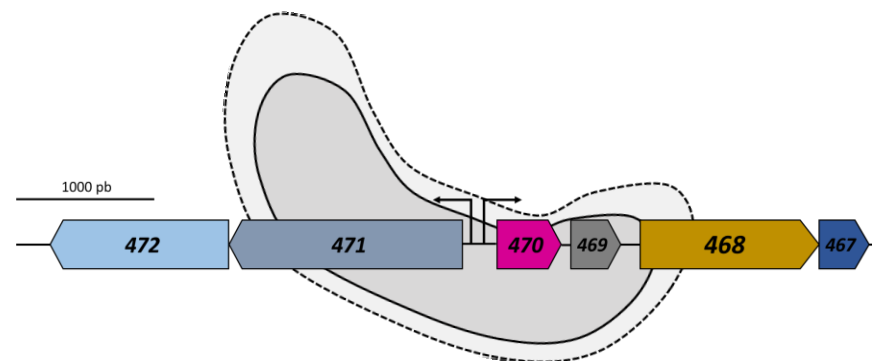

Wild type strain BerOc1



Results

3

Hg phenotype analysis

Range of Hg(II) concentrations : from 0.5 nM to 25 μ M





Results

3

Hg phenotype analysis

Range of Hg(II) concentrations : from 0.5 nM to 25 μ M

Hg(II) sensitivity

- 40 hours after Hg(II) exposure
- Production of biomass



Results

3 Hg phenotype analysis

Range of Hg(II) concentrations : from 0.5 nM to 25 μ M

Hg(II) sensitivity

- 40 hours after Hg(II) exposure
- Production of biomass

Intracellular Hg(II)

- 4 hours after Hg(II) exposure
- Cell fraction washed with Hg chelators (Glutathion/EDTA mixture)
- Measurements by GC ICP MS

Hg(II) methylation rates

- 4 hours after Hg(II) exposure
- Bulk fraction
- Measurements by GC ICP MS



Results

3 Hg phenotype analysis

Range of Hg(II) concentrations : from 0.5 nM to 25 μ M

Hg(II) sensitivity

- 40 hours after Hg(II) exposure
- Production of biomass

Intracellular Hg(II)

- 4 hours after Hg(II) exposure
- Cell fraction washed with Hg chelators (Glutathion/EDTA mixture)
- Measurements by GC ICP MS

Hg(II) methylation rates

- 4 hours after Hg(II) exposure
- Bulk fraction
- Measurements by GC ICP MS

Normalized by results obtained on the Wild type strain



Results

3

Hg phenotype analysis

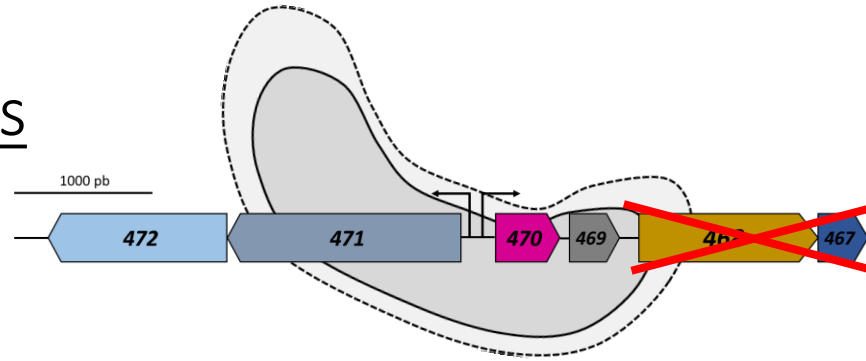

Hg(II) sensitivity



3



Results

Hg phenotype analysis

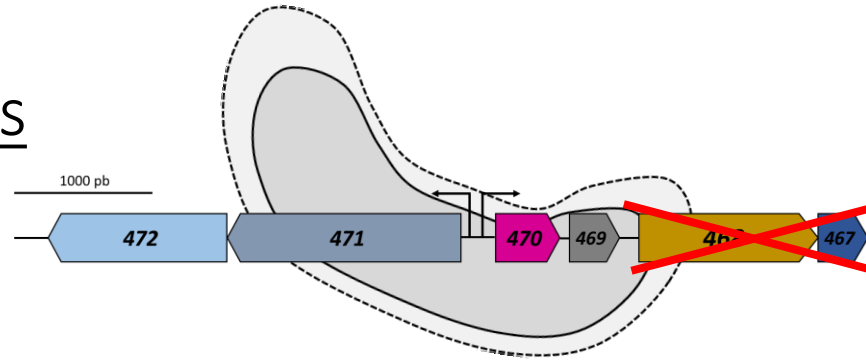

Hg(II) sensitivity

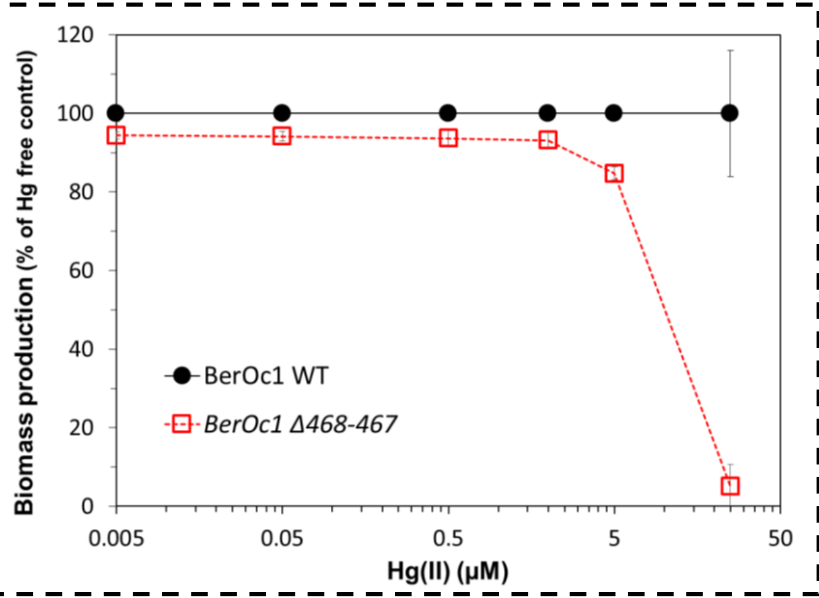

3



Results

Hg phenotype analysis

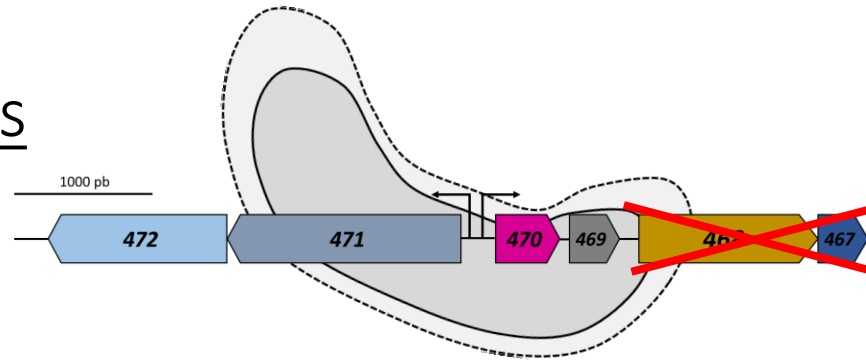

Hg(II) sensitivity

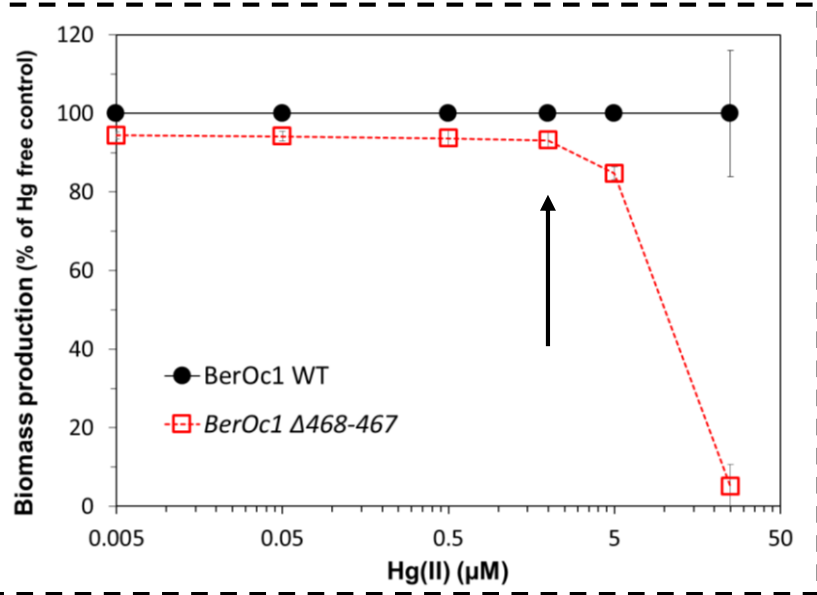

Mutant was more sensitive to Hg(II) **from 2 μM of Hg(II)**

3



Results

Hg phenotype analysis

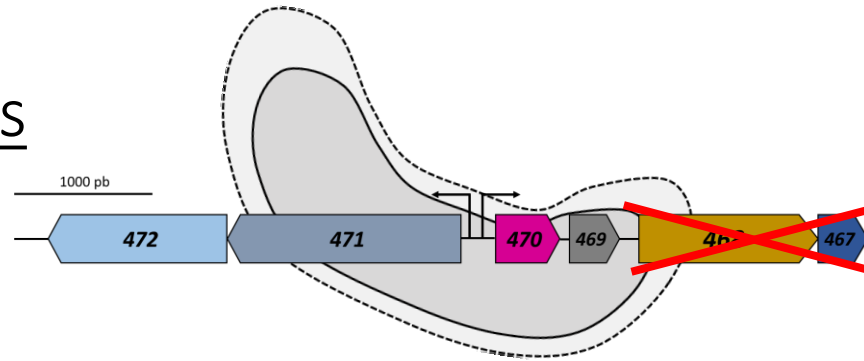

Hg(II) sensitivity

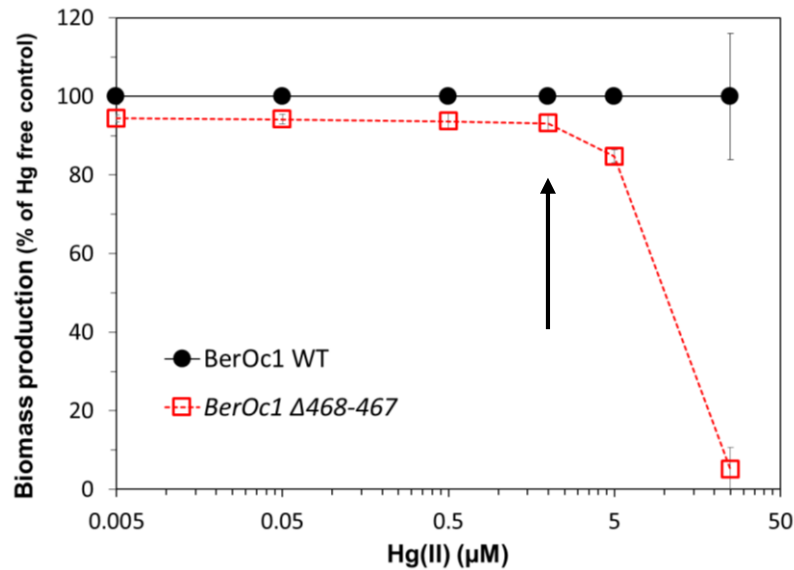

Mutant was more sensitive to Hg(II)
from 2 μM of Hg(II)

Intracellular Hg(II)

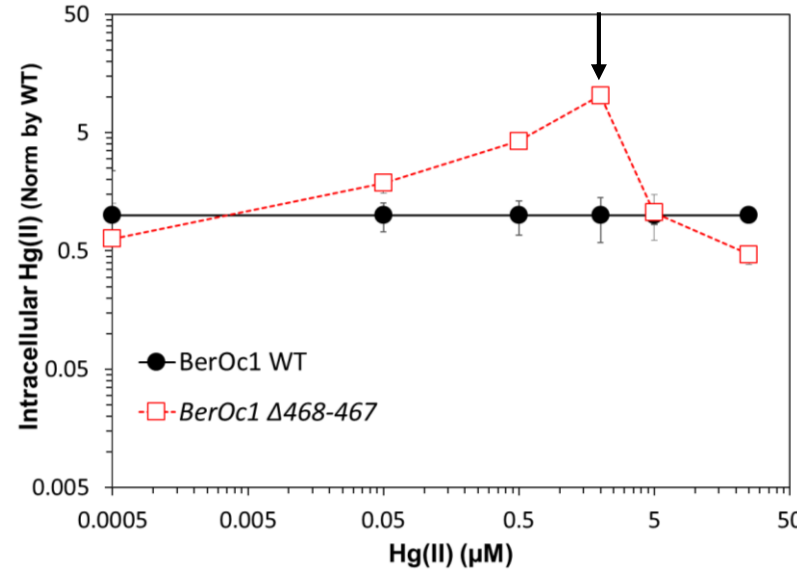

Mutant accumulated more Hg(II)
intracellularly up to 2 μM of Hg(II)

3

Results

Hg phenotype analysis

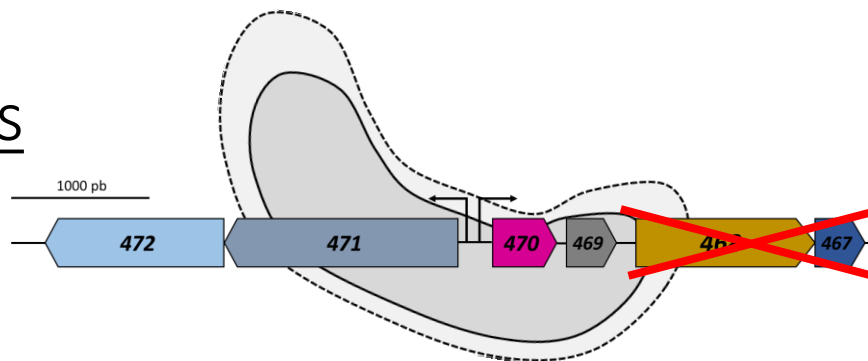

Hg(II) sensitivity

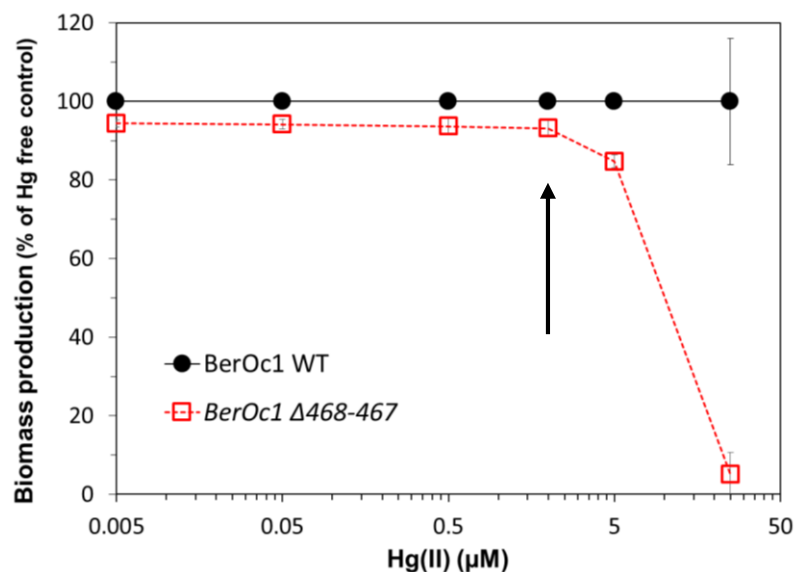

Mutant was more sensitive to Hg(II) from 2 μM of Hg(II)

Intracellular Hg(II)

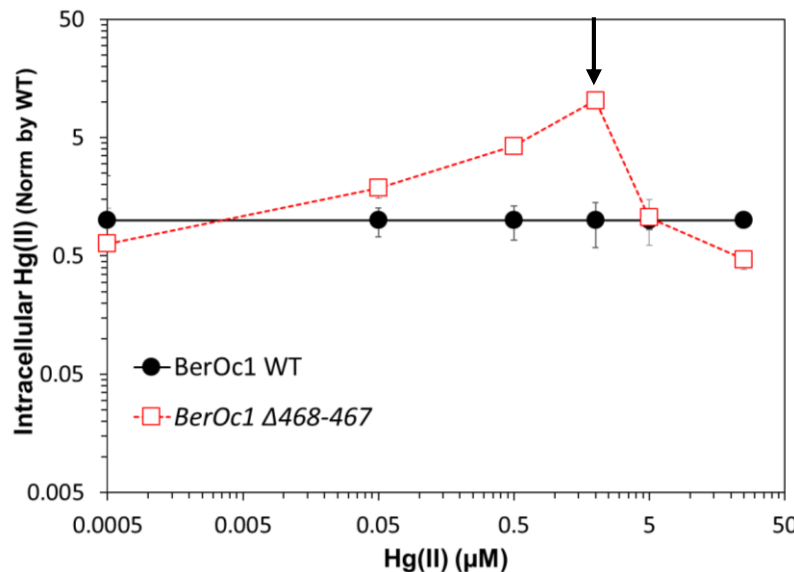

Mutant accumulated more Hg(II) intracellularly up to 2 μM of Hg(II)

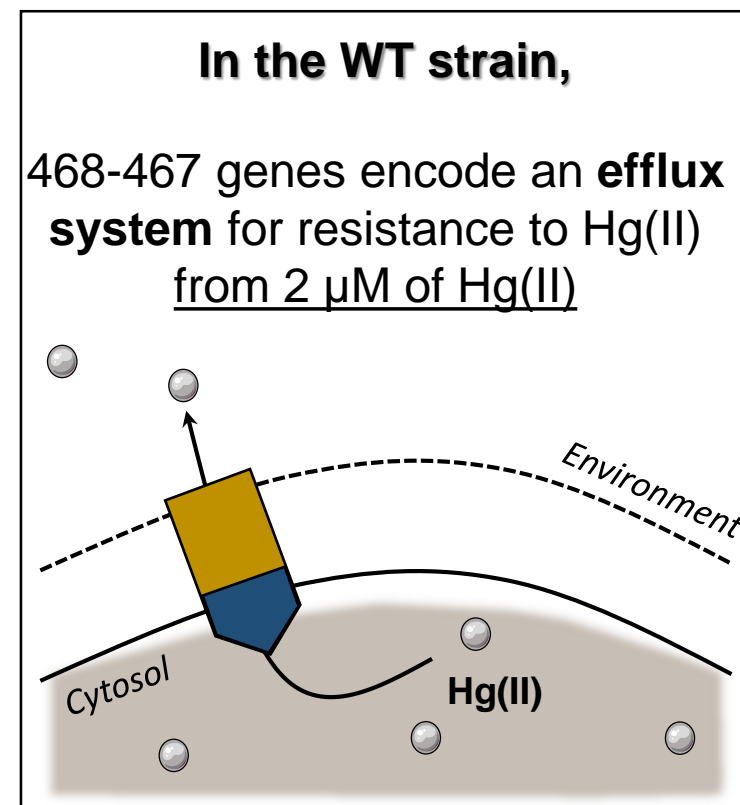

3



Results

Hg phenotype analysis

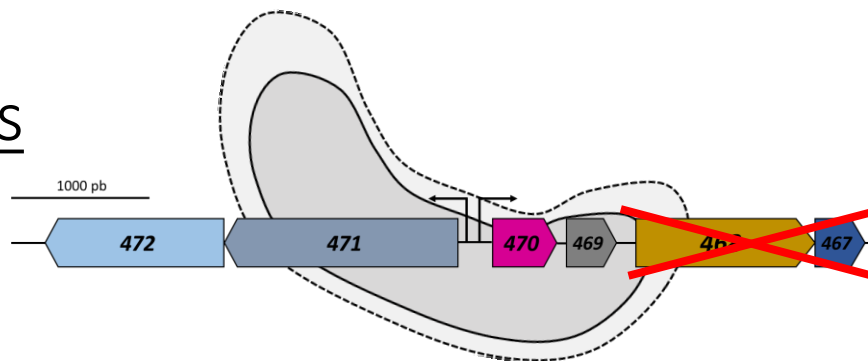

Hg(II) sensitivity

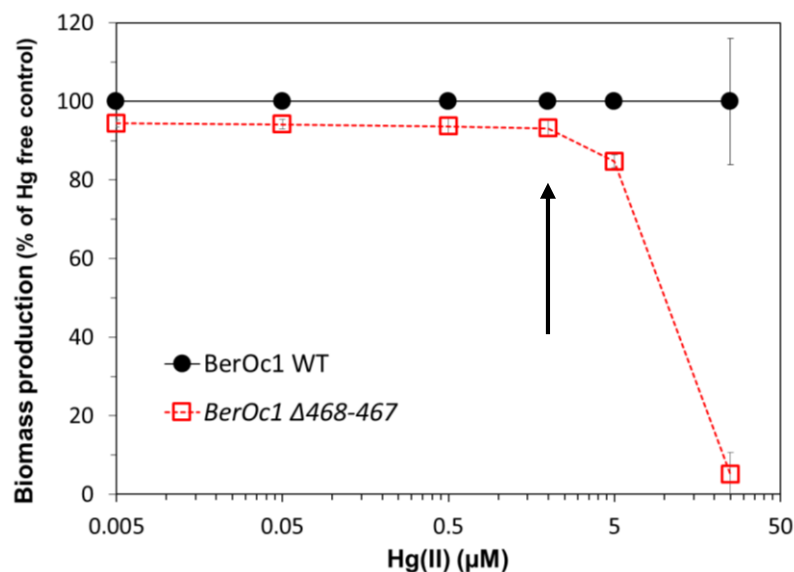

Mutant was more sensitive to Hg(II) from 2 μM of Hg(II)

Intracellular Hg(II)

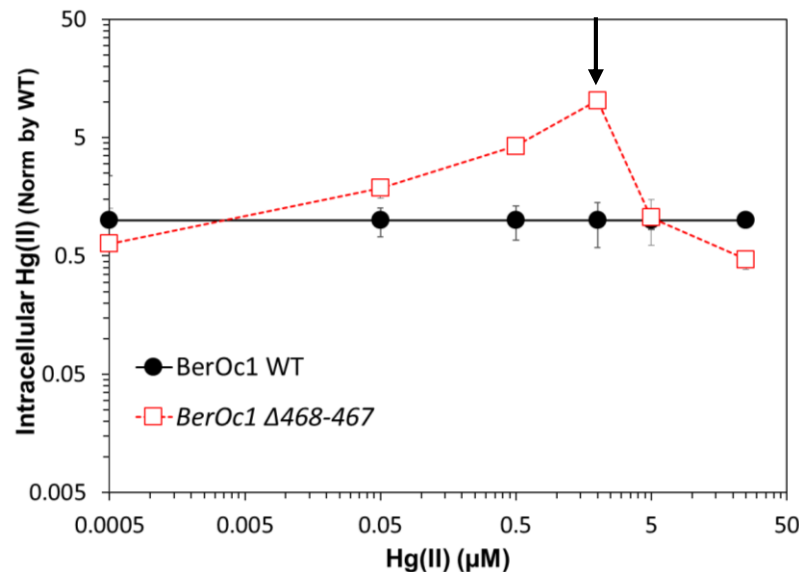

Mutant accumulated more Hg(II) intracellularly up to 2 μM of Hg(II)

Hg(II) methylation rates

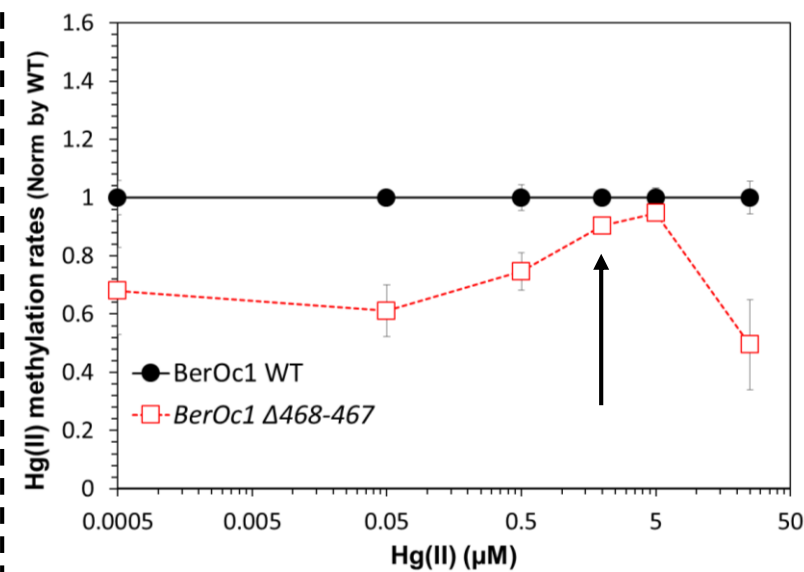

Surprisingly, mutant methylated less than WT up to 2 μM of Hg(II)



Results

3

Hg phenotype analysis

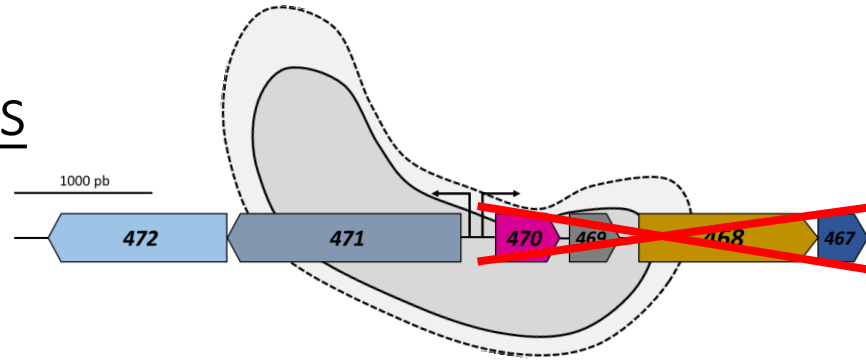

Hg(II) sensitivity





Results

3 Hg phenotype analysis

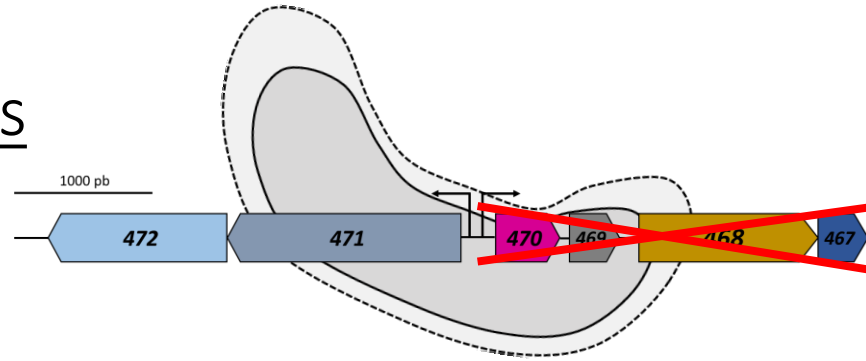

Hg(II) sensitivity

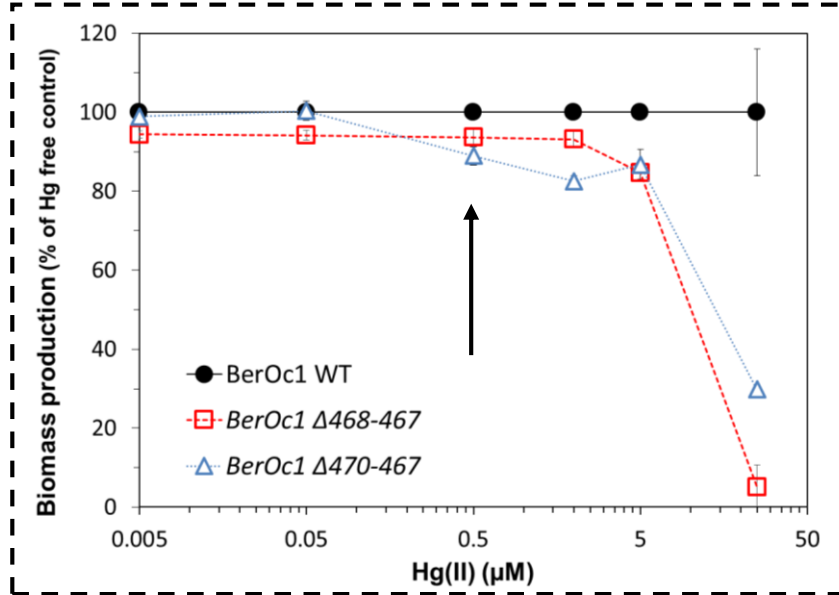

Mutant was more sensitive to Hg(II) from 0.5 μM of Hg(II)



Results

3 Hg phenotype analysis

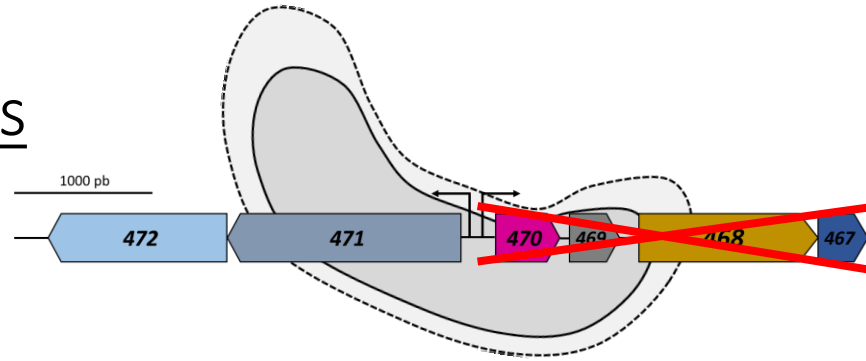

Hg(II) sensitivity

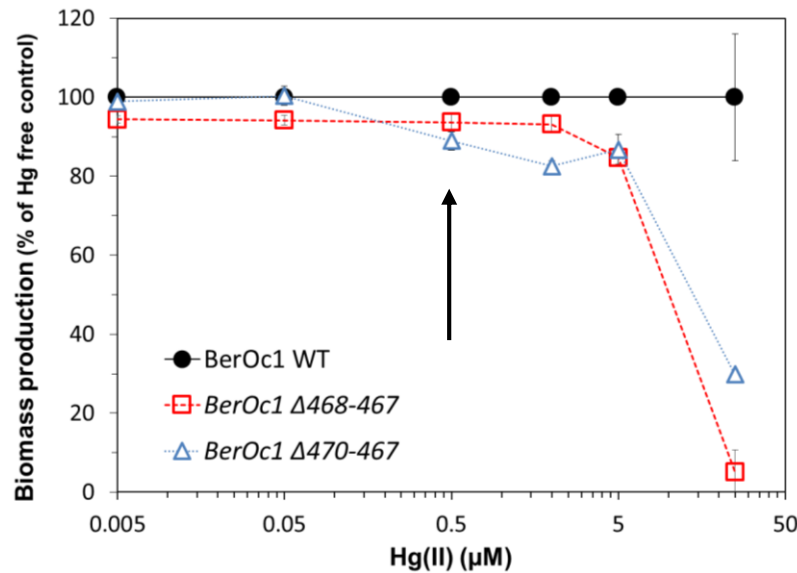

Mutant was more sensitive to Hg(II) from 0.5 μM of Hg(II)

Intracellular Hg(II)

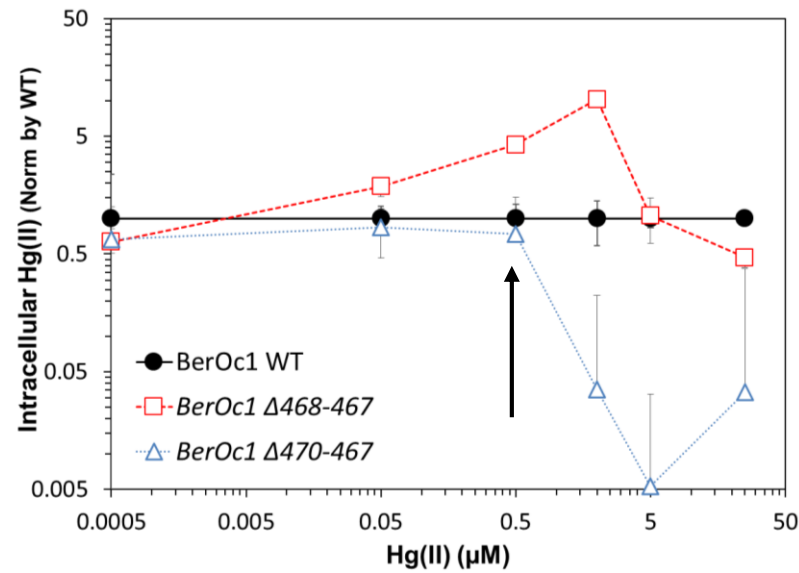

Mutant accumulated less Hg(II) intracellularly from 0.5 μM of Hg(II)

3



Results

Hg phenotype analysis

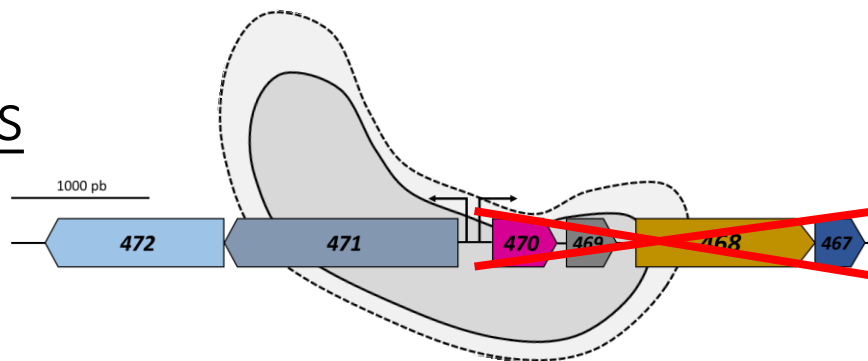

Hg(II) sensitivity

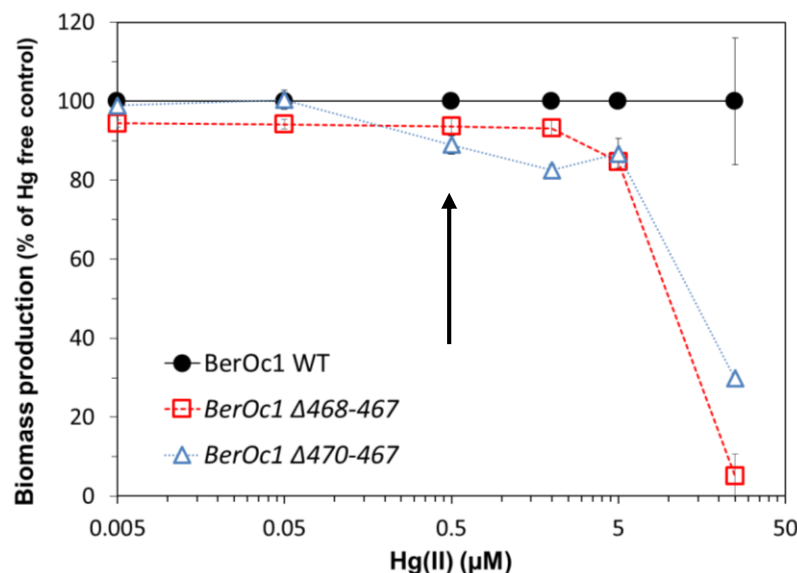

Mutant was more sensitive to Hg(II) from 0.5 μM of Hg(II)

Intracellular Hg(II)

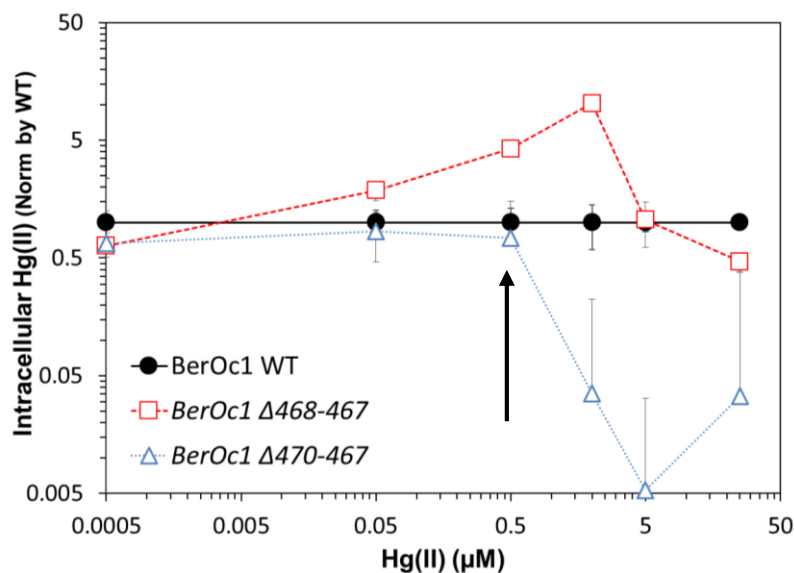

Mutant accumulated less Hg(II) intracellularly from 0.5 μM of Hg(II)

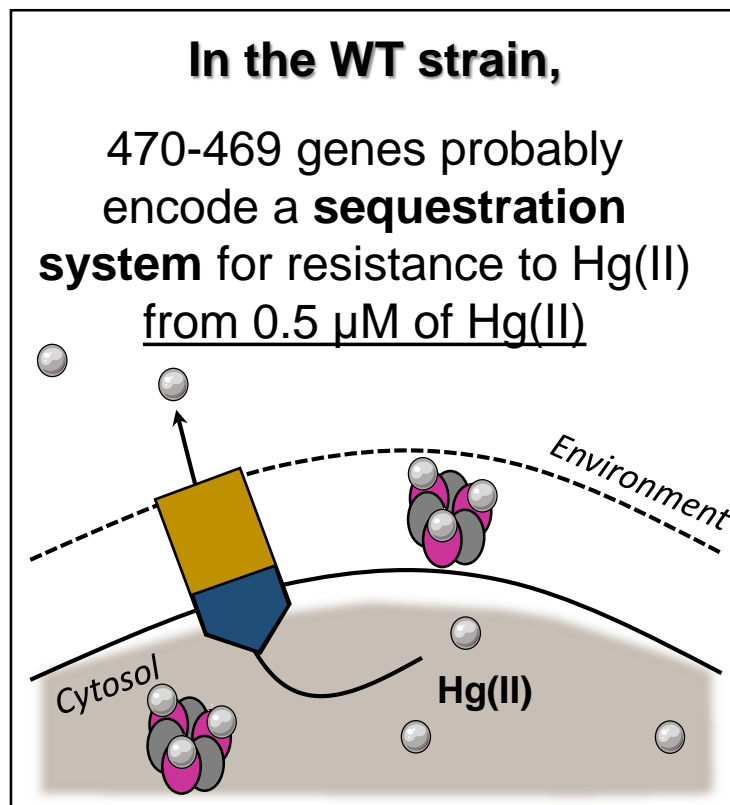

3



Results

Hg phenotype analysis

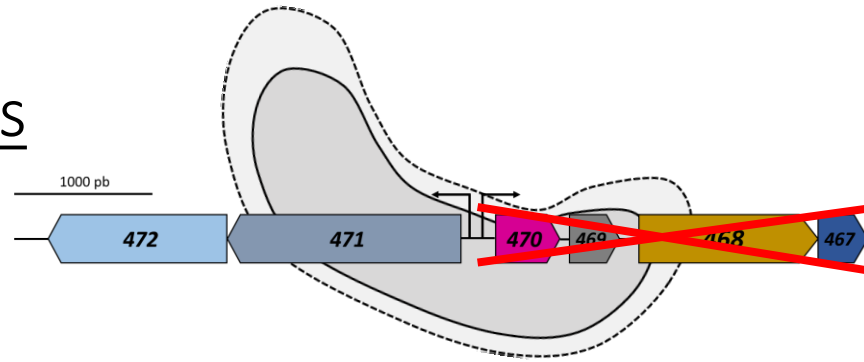

Hg(II) sensitivity

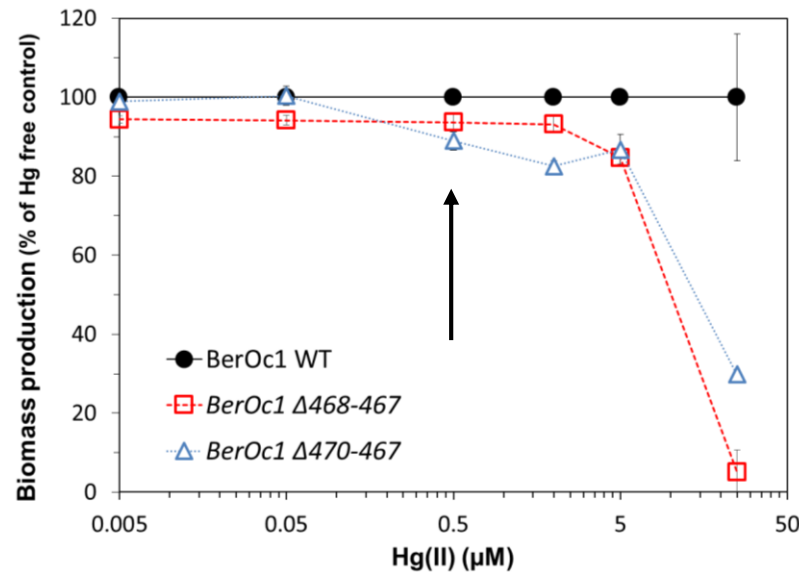

Mutant was more sensitive to Hg(II) from 0.5 μM of Hg(II)

Intracellular Hg(II)

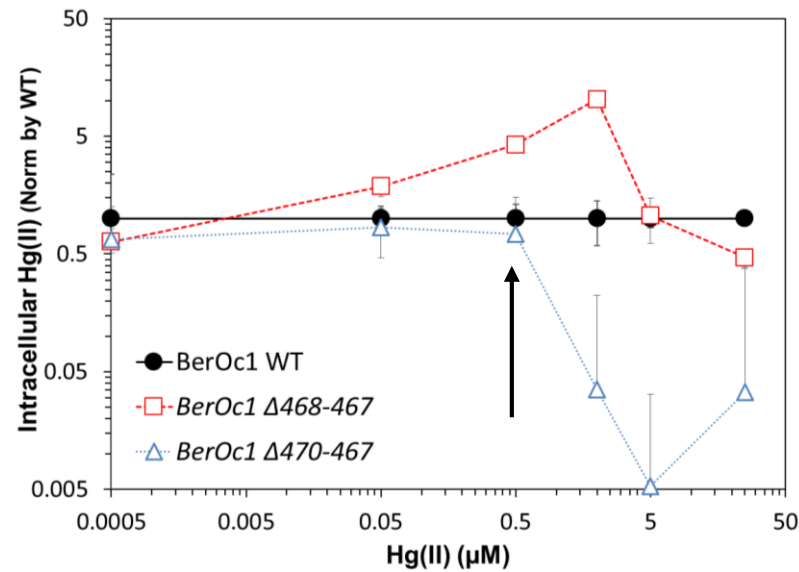

Mutant accumulated less Hg(II) intracellularly from 0.5 μM of Hg(II)

Hg(II) methylation rates

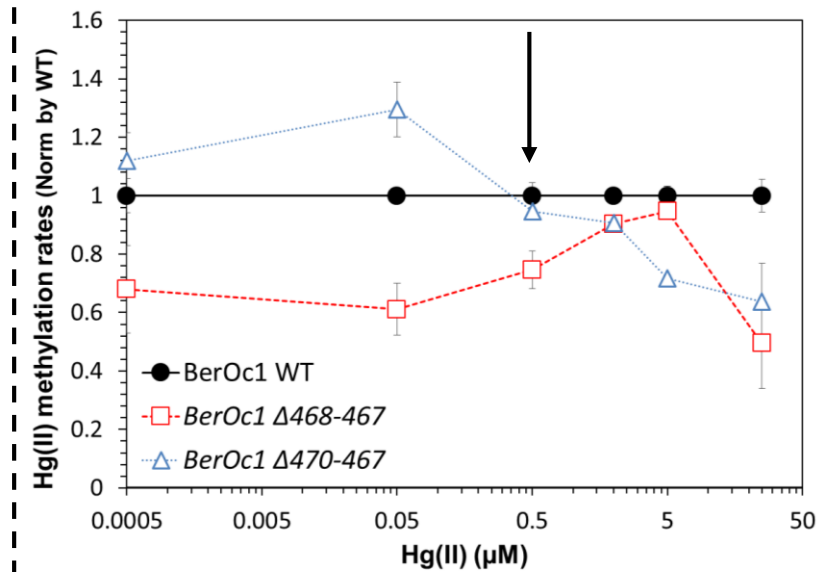

Consequently, mutant methylated less than WT from 0.5 μM of Hg(II)



Conclusions

- ✓ First evidence of a mercury resistance mechanism in an anaerobic bacterium



Conclusions

- ✓ First evidence of a mercury resistance mechanism in an anaerobic bacterium
- ✓ Two resistance systems:
 - ✓ A sequestration system → 470-469 genes
 - ✓ An efflux system → 468-467 genes



Conclusions

- ✓ First evidence of a mercury resistance mechanism in an anaerobic bacterium
- ✓ Two resistance systems:
 - ✓ A sequestration system → 470-469 genes
 - ✓ An efflux system → 468-467 genes
- ✓ Hg(II) is the signal that triggers the resistance mechanism via a two components systems → 471-472 genes



Take Home Message

Model of Hg(II) resistance mechanism in anaerobic microorganisms

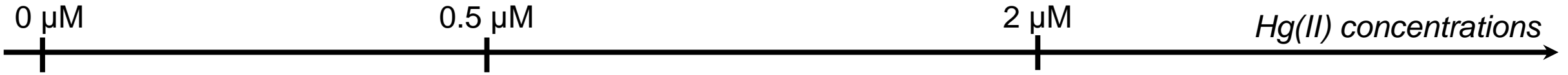



Take Home Message

Model of Hg(II) resistance mechanism in anaerobic microorganisms

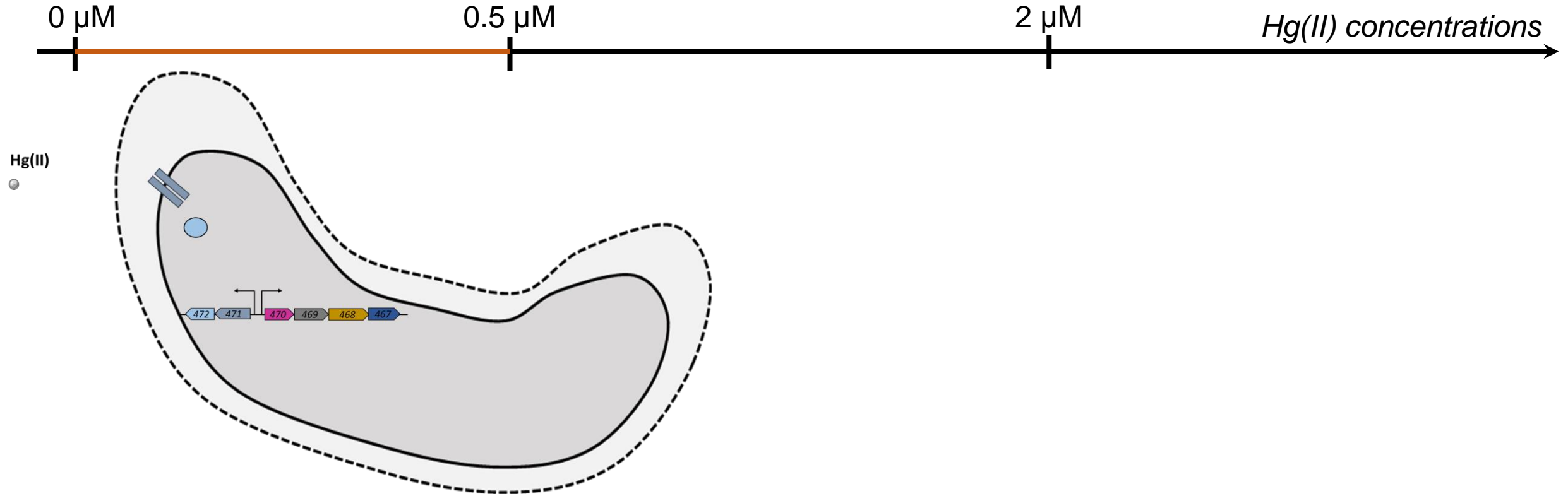



Take Home Message

Model of Hg(II) resistance mechanism in anaerobic microorganisms

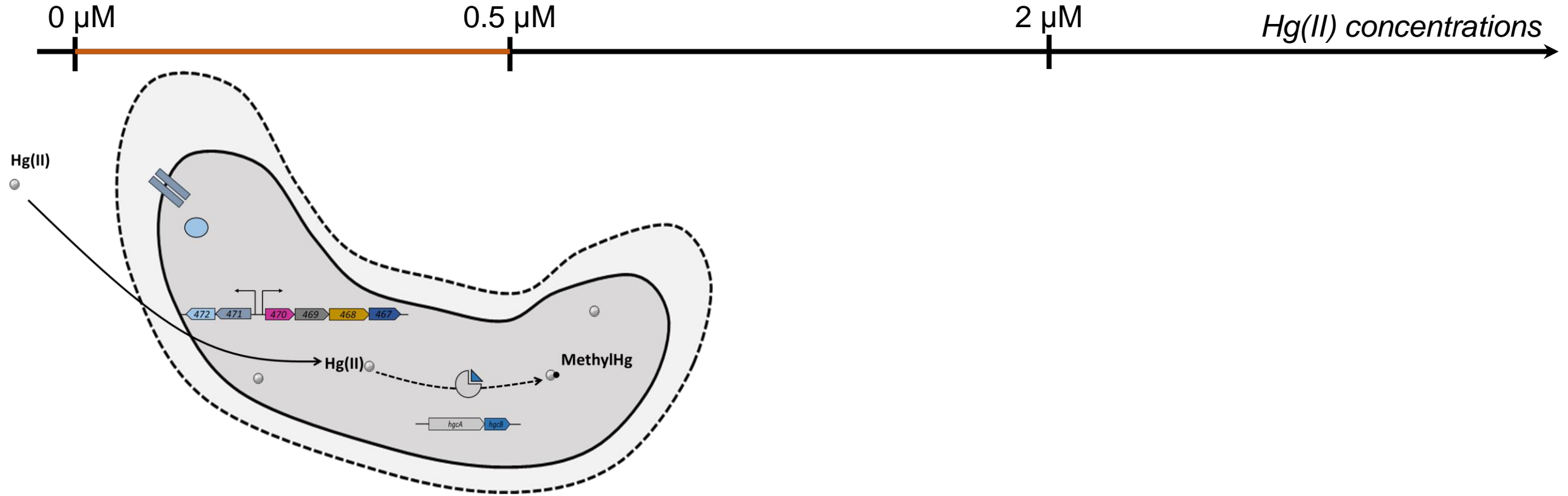



Take Home Message

Model of Hg(II) resistance mechanism in anaerobic microorganisms

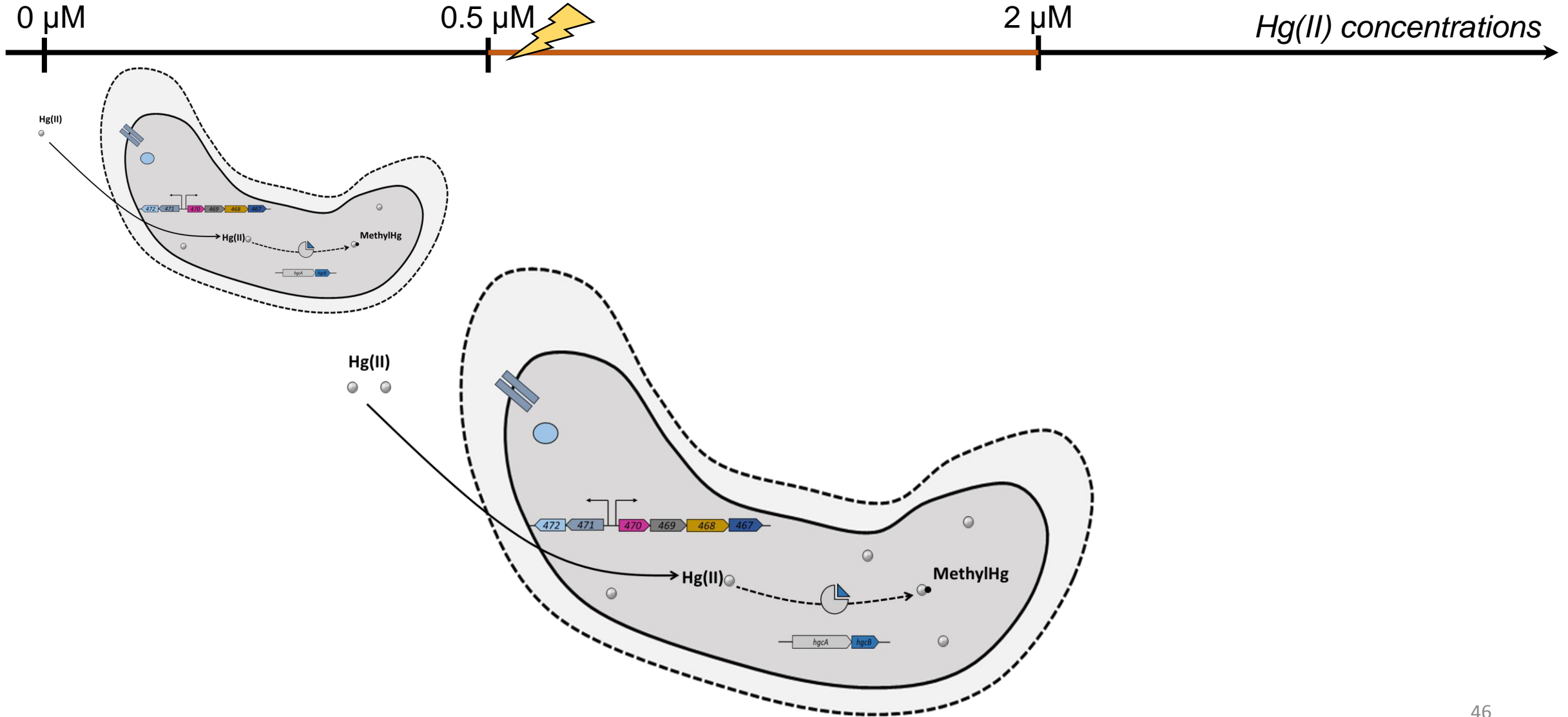



Take Home Message

Model of Hg(II) resistance mechanism in anaerobic microorganisms

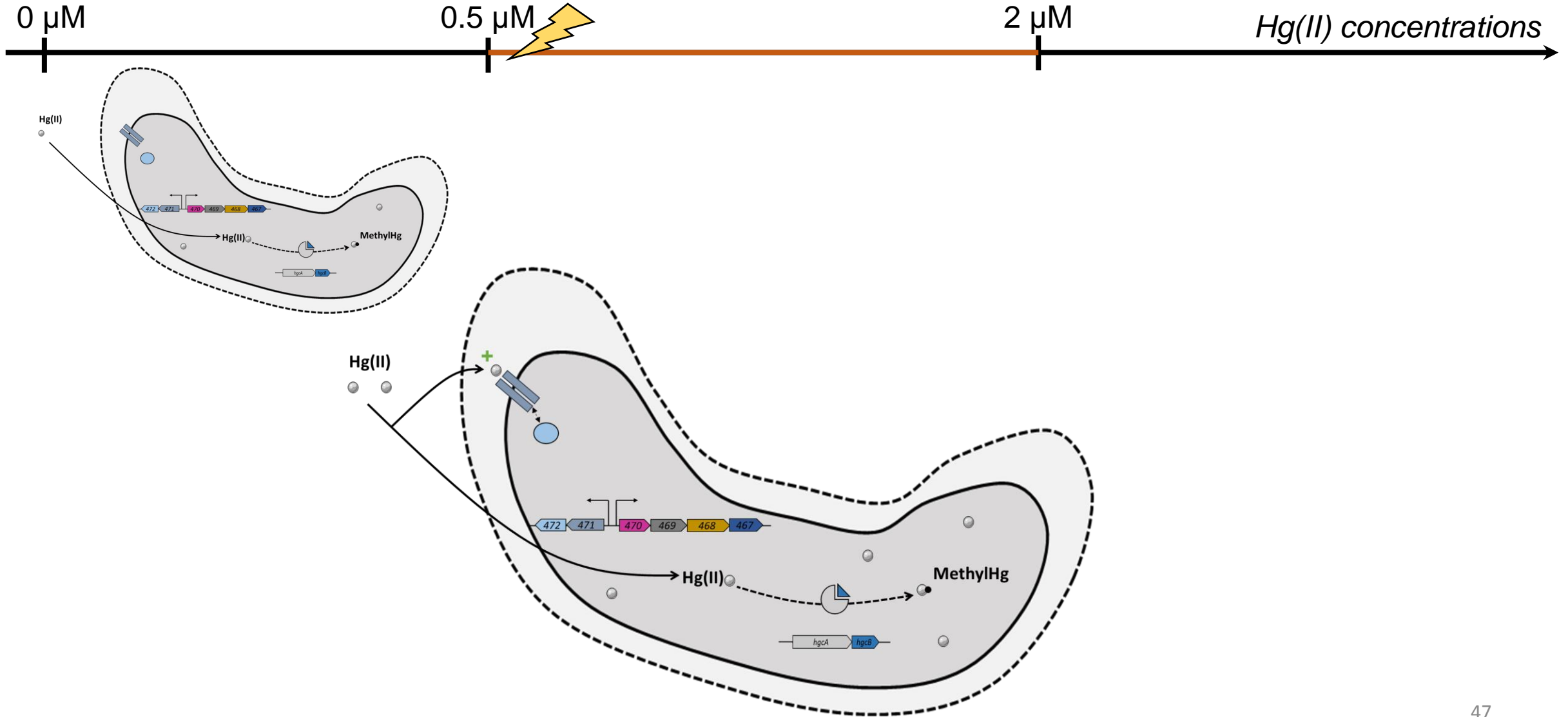



Take Home Message

Model of Hg(II) resistance mechanism in anaerobic microorganisms

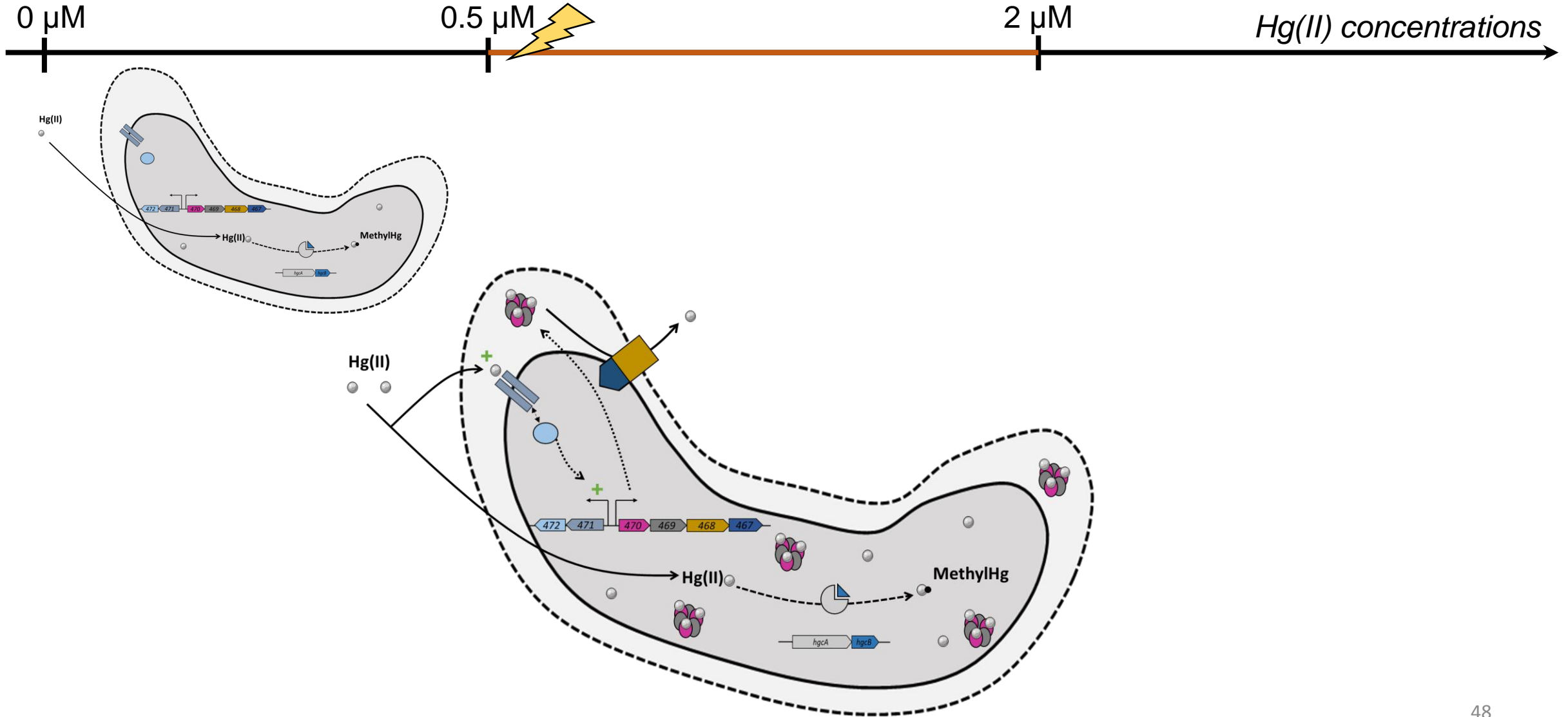



Take Home Message

Model of Hg(II) resistance mechanism in anaerobic microorganisms

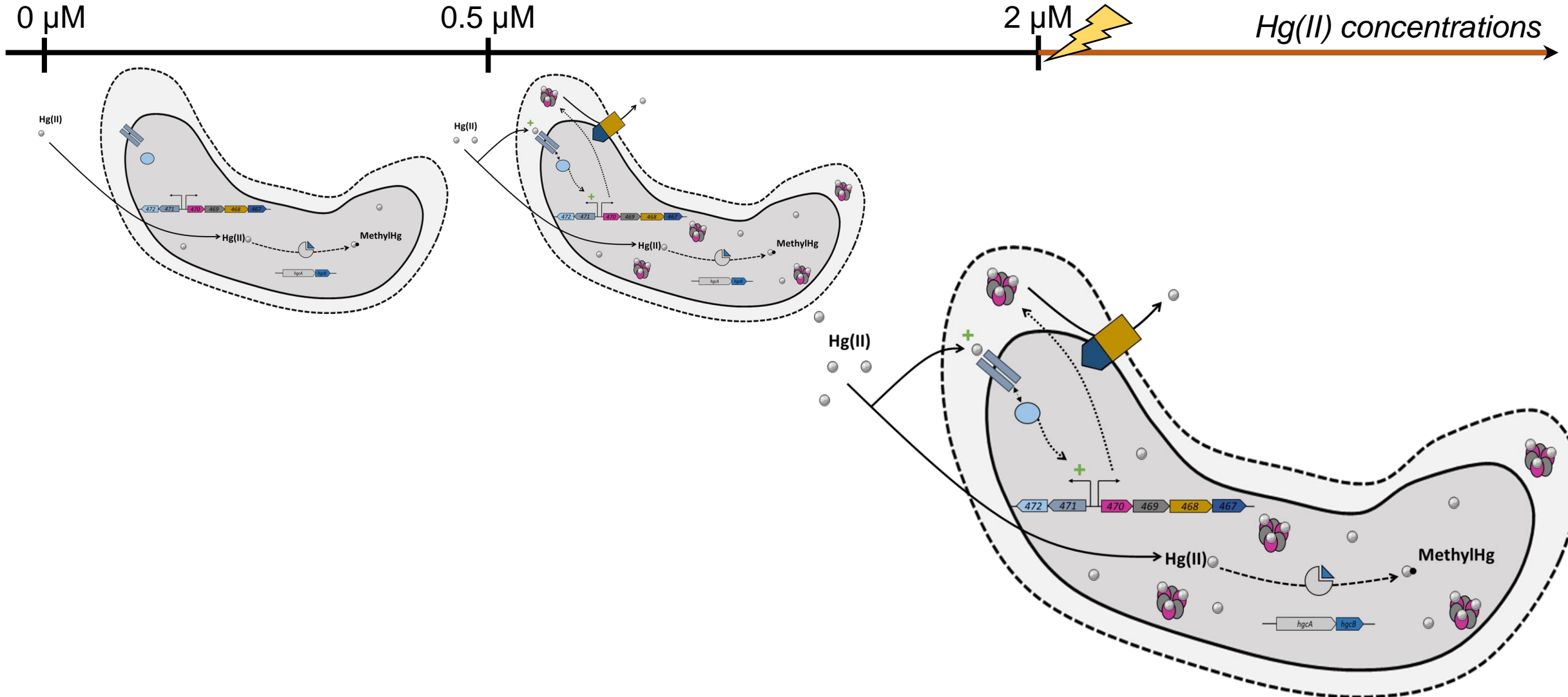



Take Home Message

Model of Hg(II) resistance mechanism in anaerobic microorganisms

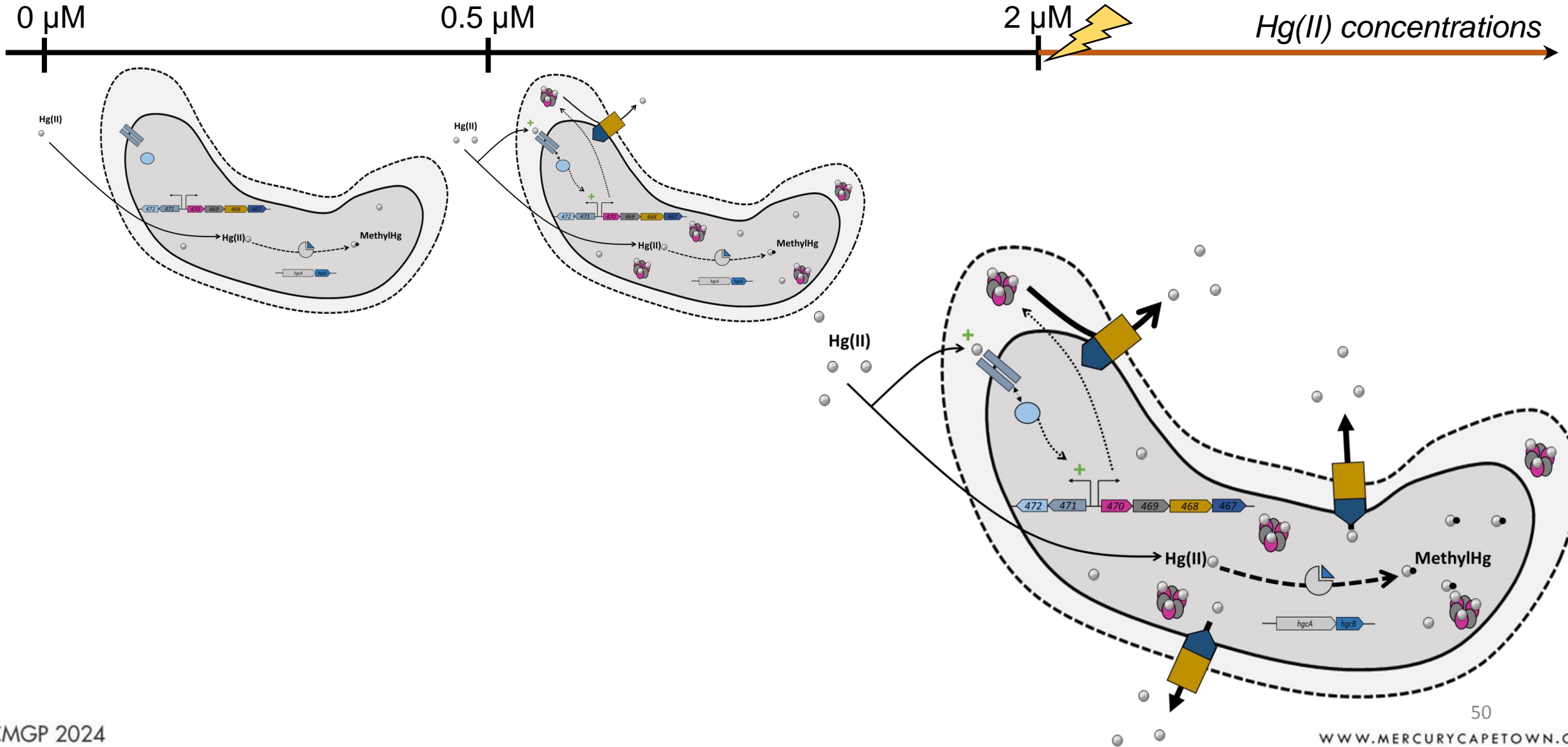

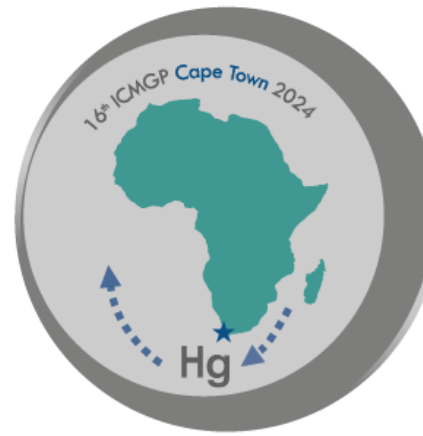

ICMGP 2024

CAPE TOWN • SOUTH AFRICA • 21 - 26 JULY
CAPE TOWN INTERNATIONAL CONVENTION CENTRE



Association francophone d'écologie microbienne

Thank you for your attention



IPREM

Institut des sciences analytiques
et de physico-chimie
pour l'environnement et les matériaux



energy environment solutions



Agence Nationale de la Recherche

ANR



UNIVERSITÉ
DE PAU ET DES
PAYS DE L'ADOUR

COLLÈGE STEE
SCIENCES ET TECHNOLOGIES
POUR L'ÉNERGIE ET L'ENVIRONNEMENT