



ICMGP 2024
CAPE TOWN • SOUTH AFRICA • 21 - 26 JULY

Toward a GC-MS method for quantification & characterization of ambient gaseous oxidized mercury compounds

Sarrah M. Dunham-Cheatham¹, Seth N. Lyman², Livia Lown¹,
Jan Gačnik¹, Trevor O'Neil², Mae S. Gustin¹



Motivation: Hg^{II} Analytical Method

Global Goal = development of an analytical technique that is:

- Field-based
- Calibrated
- Chemically resolved
- Direct measurement of ambient Hg^{II} forms and compounds



Many efforts have been made toward this goal, but:

- A single method is not yet available
- Existing methods have limitations

Background: Hg-N in Flue Gas by GC-MS

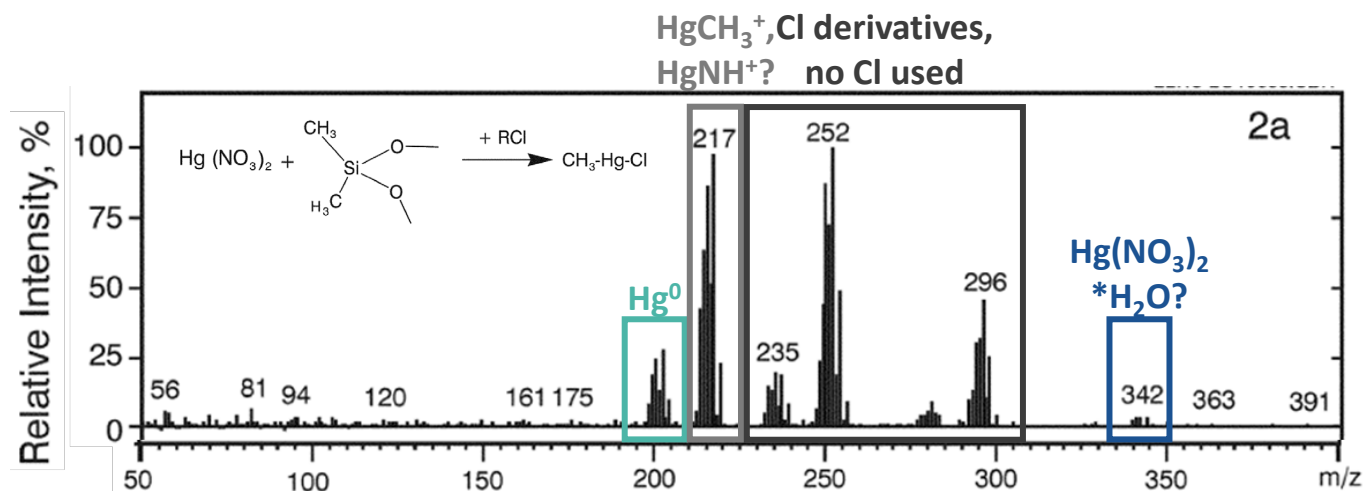
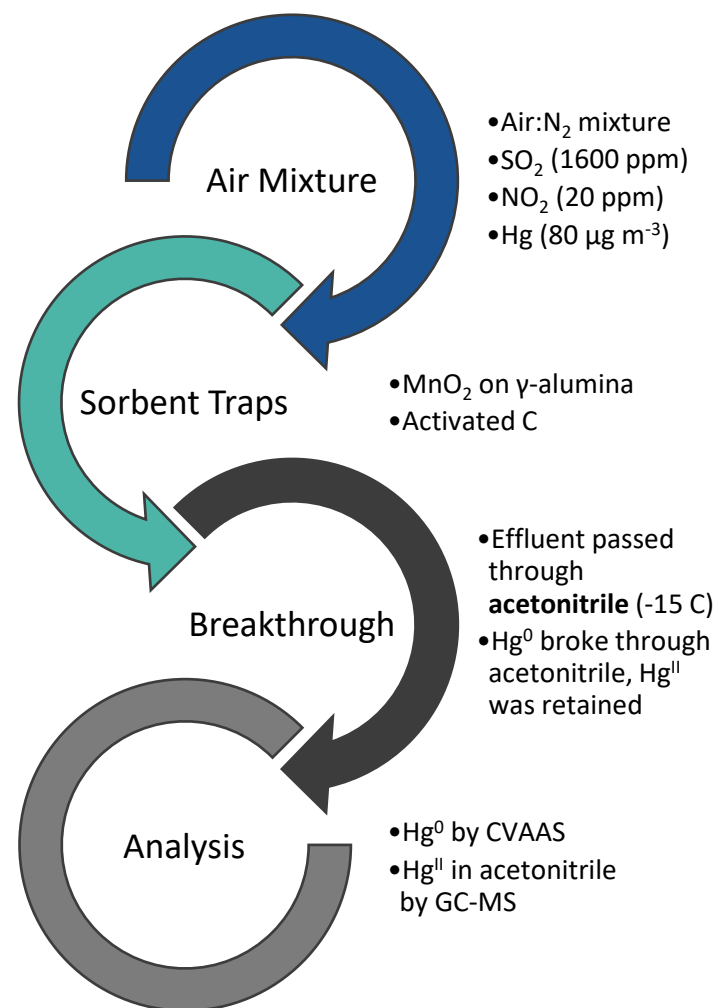

Limitations

- Reaction between Hg-N compounds and the PDMS GC column
- Same results for Hg(NO₃)₂ and Hg(NO₃)₂-N₂O₄, which should not be the case
- Unstable calibration using solutions
- Assignment of rational formulas to m/z signals was problematic
- Suggested only qualitative results are possible

Background: Hg Halides by APCI-MS

target species (M)	phase	reagent gas/ solvent
HgCl ₂ (IP = 11.380 eV)	aqueous	distilled water
		acetonitrile ^b
		ethanol ^b
	gas	isopropanol ^b
		N ₂
		N ₂ ^b
HgBr ₂ (IP = 10.560 eV)	aqueous	C ₂ H ₂ F ₄ /N ₂
		isobutane/N ₂ ^b
	gas	SF ₆ /isobutane ^d
		ethanol
		He
		Ar
		N ₂
		H ₂
		acetylene/N ₂
		isobutane/N ₂ ^b
acetone/N ₂		
HgO	aqueous	SF ₆ /isobutane
		NO ₂ /N ₂
		benzene/N ₂
		distilled water



Successes

- Preconcentration of HgX₂ followed by thermal release into the analyzer is possible (implications for portability)
- Both HgCl₂ and HgBr₂ were detected in ambient air
- Detection limit: 6-40 pg HgX₂

Limitations

- Only successful for HgX₂ compounds
- Requires 1 day of loading
- Suffers from interferences with other ambient air compounds

Background: Gaseous Hg^{II} by GC-MS

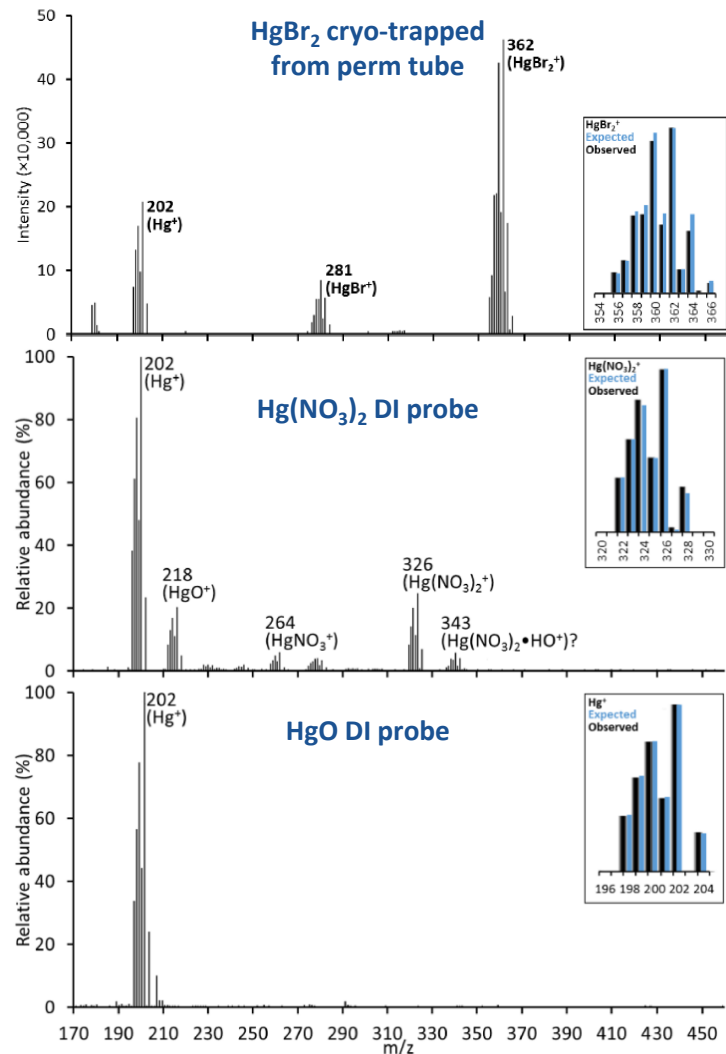

Successes

- -MS confirmation of HgX₂ compounds
- Chromatographic separation of HgX₂ mixtures
- Development of cryo-trapping technique for ambient air sampling

Limitations

- HgO and Hg(NO₃)₂ spectra were not detected from permeation tubes
- HgO not detectable using this method

Objective: GC-MS Method for Hg^{II} Compounds

- Develop a GC-MS method(s) for more Hg^{II} compounds that can be used with ambient air samples

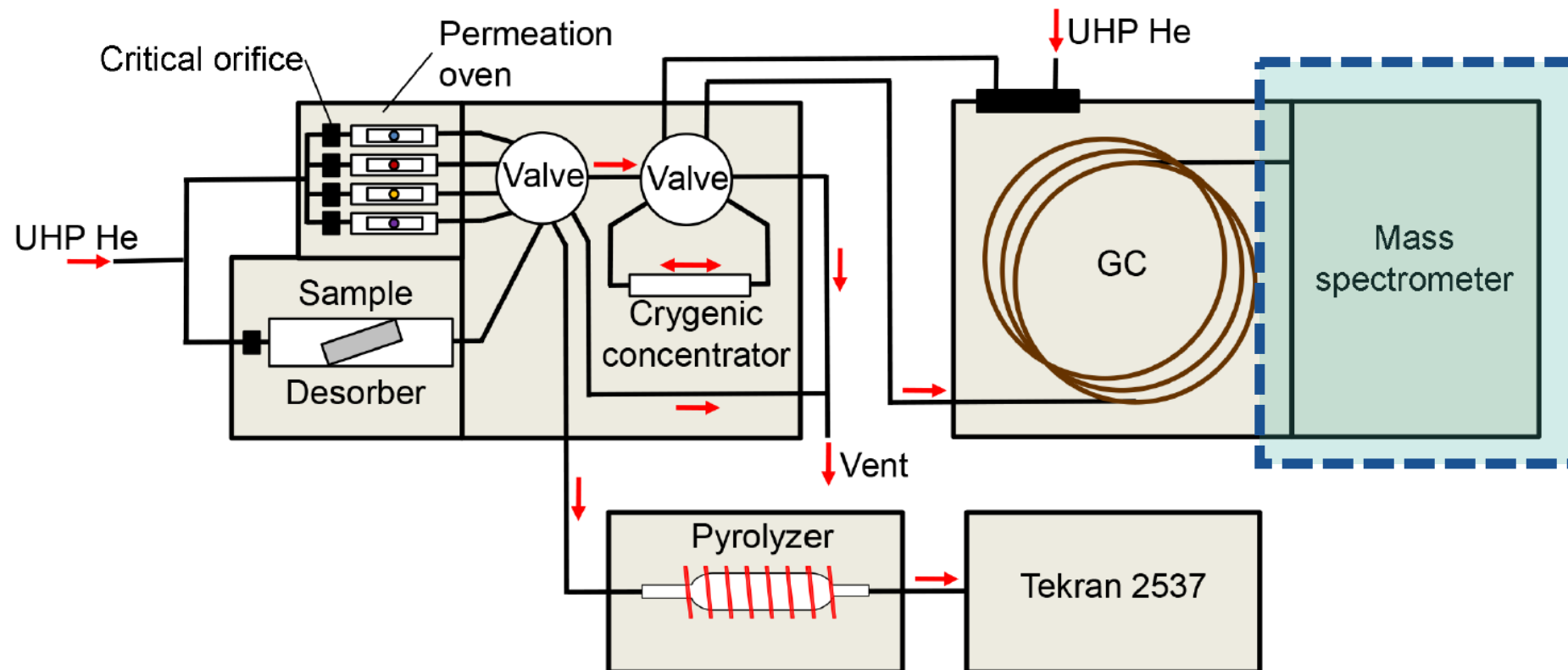

Direct Injections to –MS in EI vs CI

- Load Hg^{II} salts or Hg^{II} solutions into test tubes for direct analysis
 - Optimize detector lens voltages
- Electron vs. Chemical Ionization

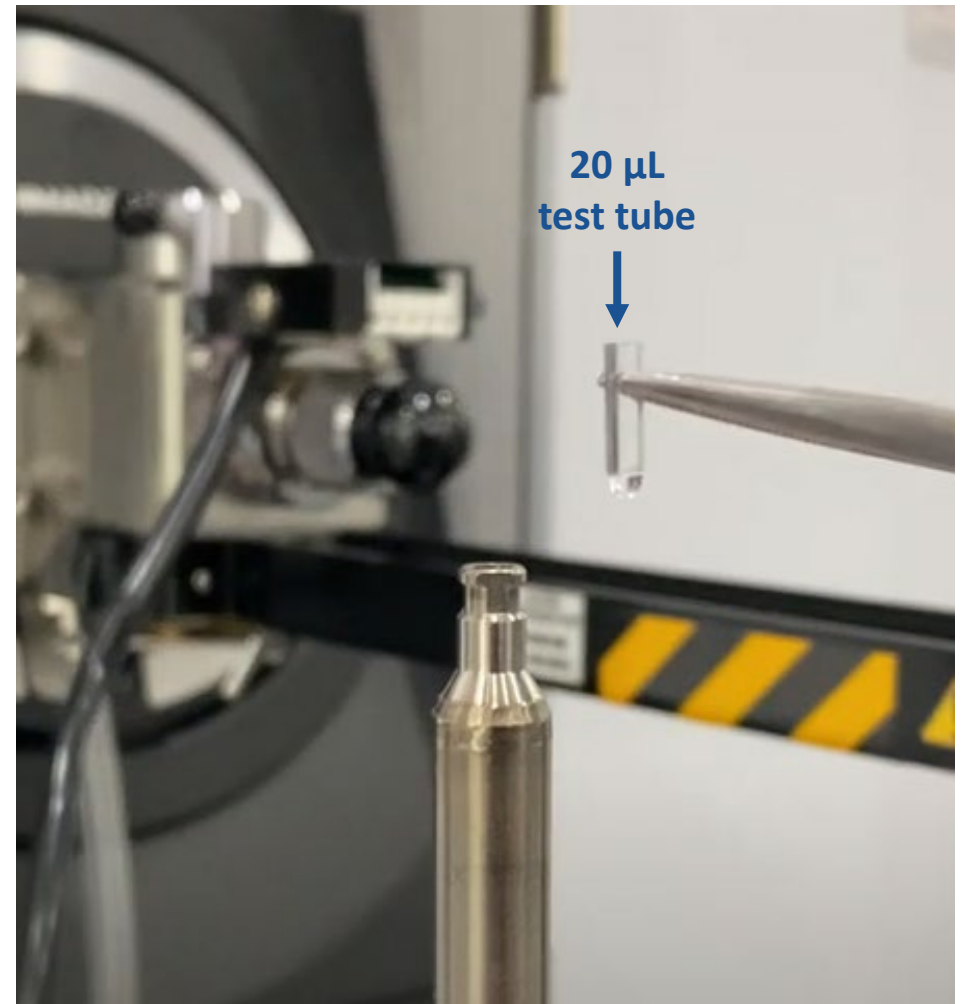
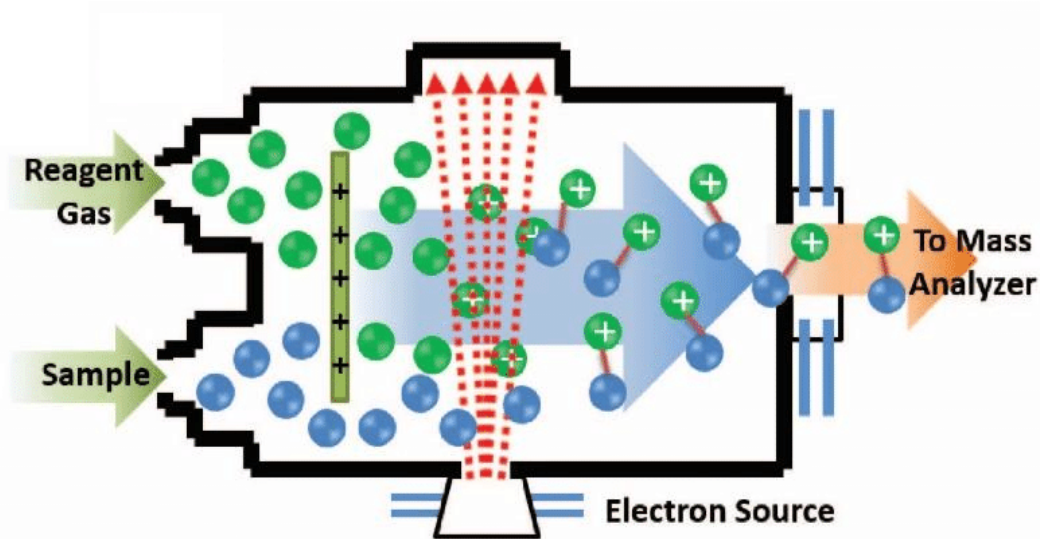

Hg^{II} in EI Mode: Halides

HgBr₂

- Rational ions are present
- Match well with Jones et al. (2016) results

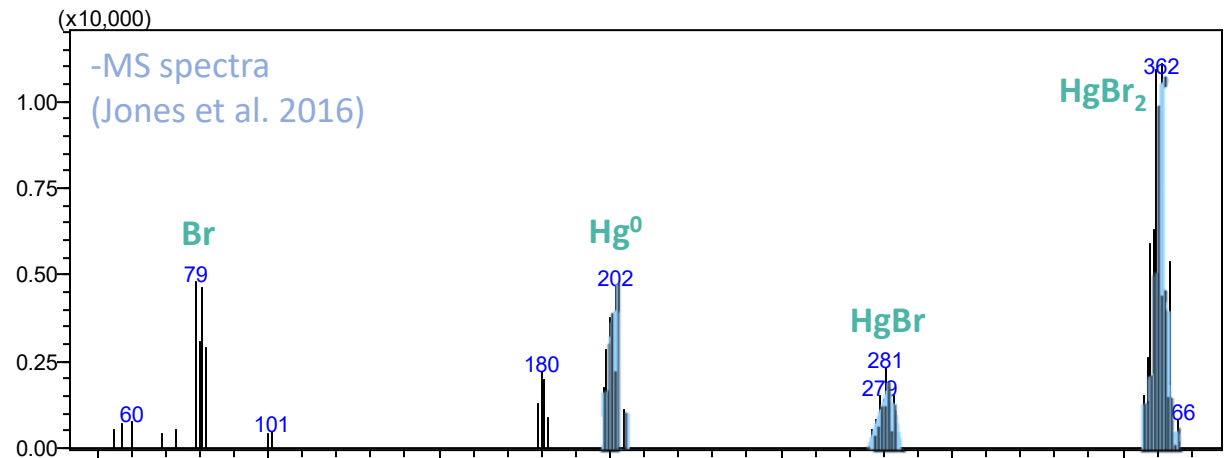

HgCl₂

- Rational ions are present
- Match well with Jones et al. (2016) results, with less fragmentation

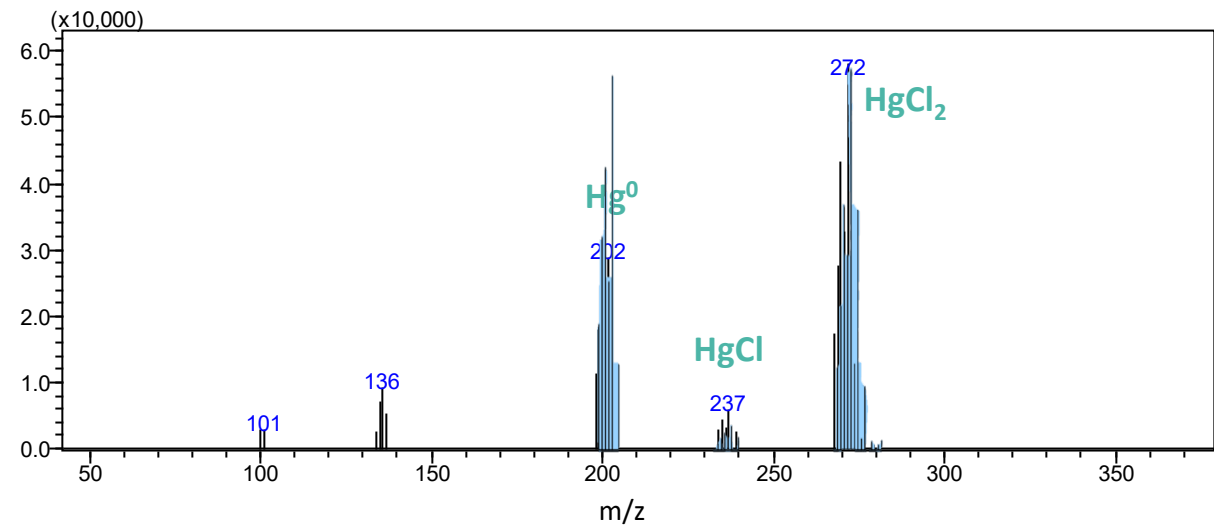

Hg^{II} in EI Mode: Other Compounds

Hg(NO₃)₂·H₂O

- Rational degradation products are not detected
- HgO is detected

HgO

- No strong, replicable HgO signal

HgSO₄

- No signal detected

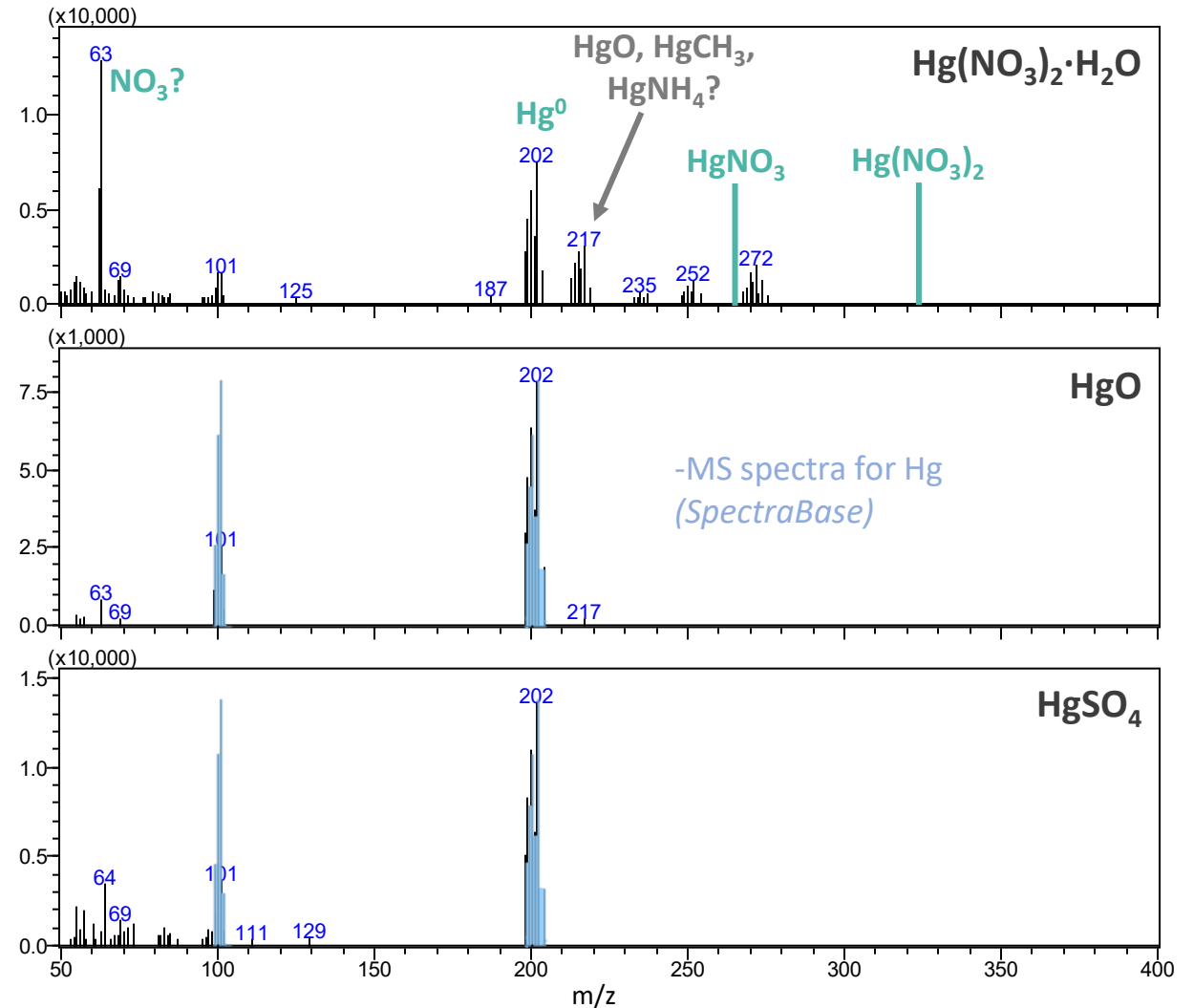

Hg^{II} in CI Mode: Halides

Reagent Gas:
isobutane
 $m/z+43$ & $m/z+57$
IP: 10.68 eV

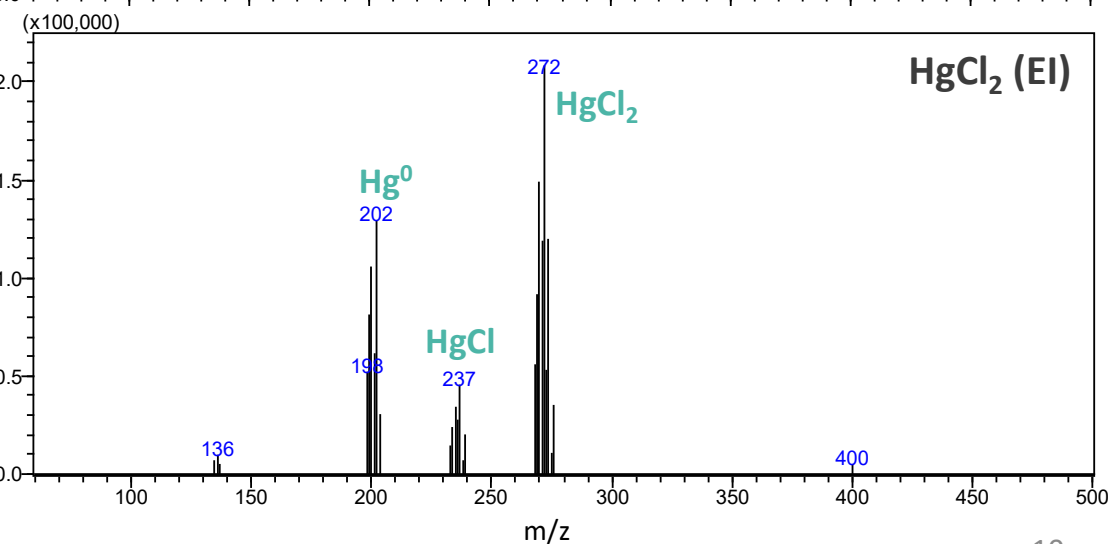
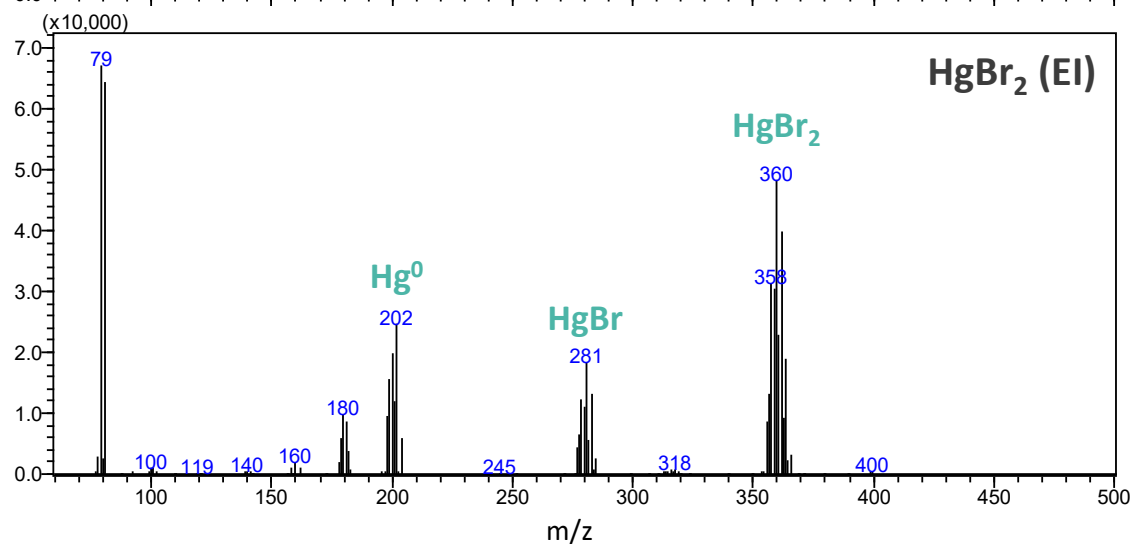
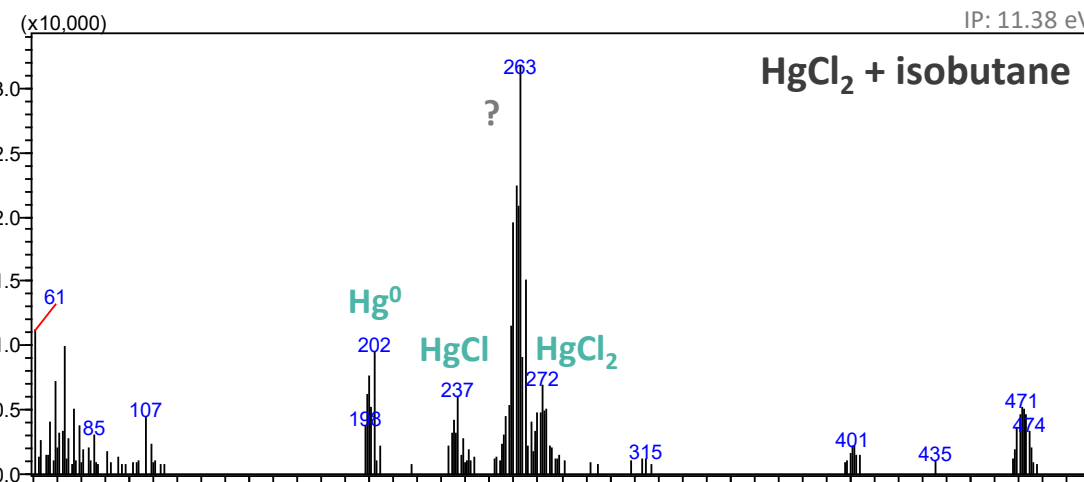
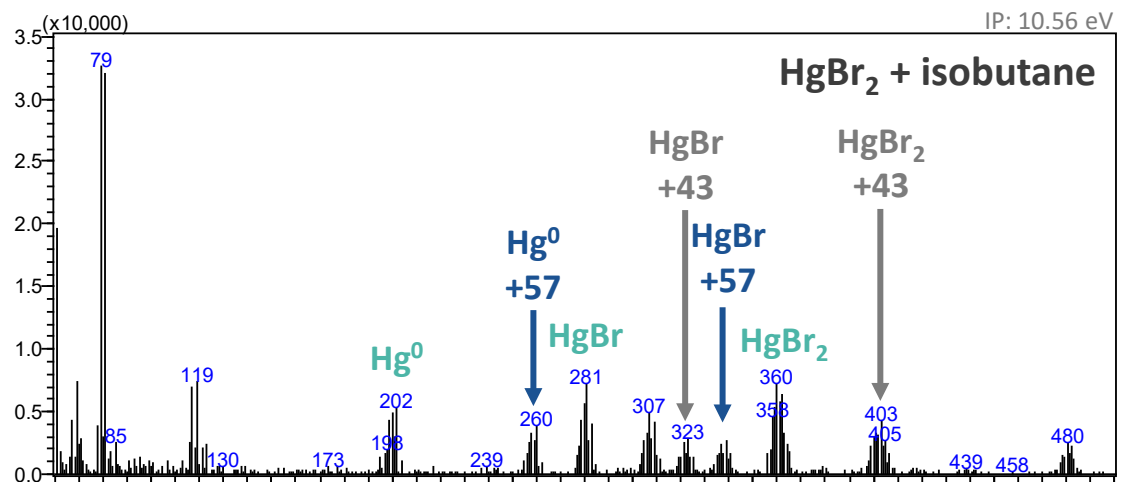
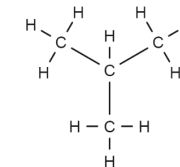

Reagent Gas:
isobutane
 $m/z+43$ & $m/z+57$

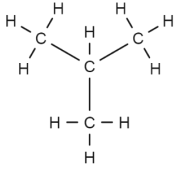

Hg^{II} in CI Mode: Other Compounds

- No signal for HgO nor HgSO₄
- Weak signal for Hg(NO₃)₂·H₂O, but rational ions are absent

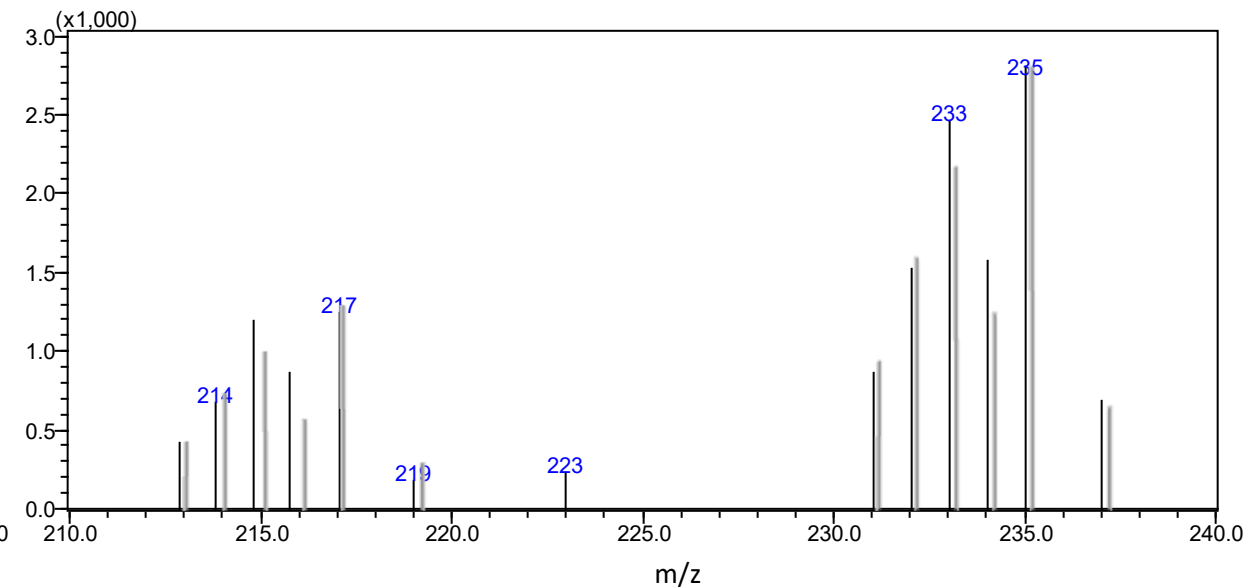
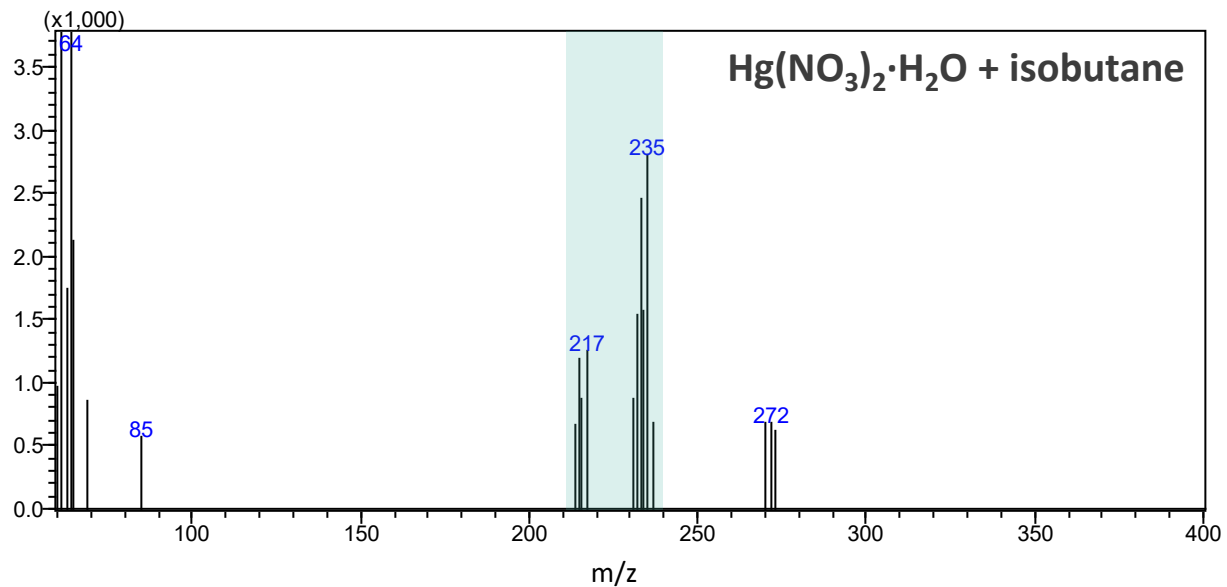

Hg(NO₃)₂ + Acetonitrile

- Hg(NO₃)₂·H₂O salt does not yield a strong signal when directly inserted into the -MS
- When mixed with acetonitrile, following Olson et al. (2002), rational ions are now present
 - Mechanism under investigation

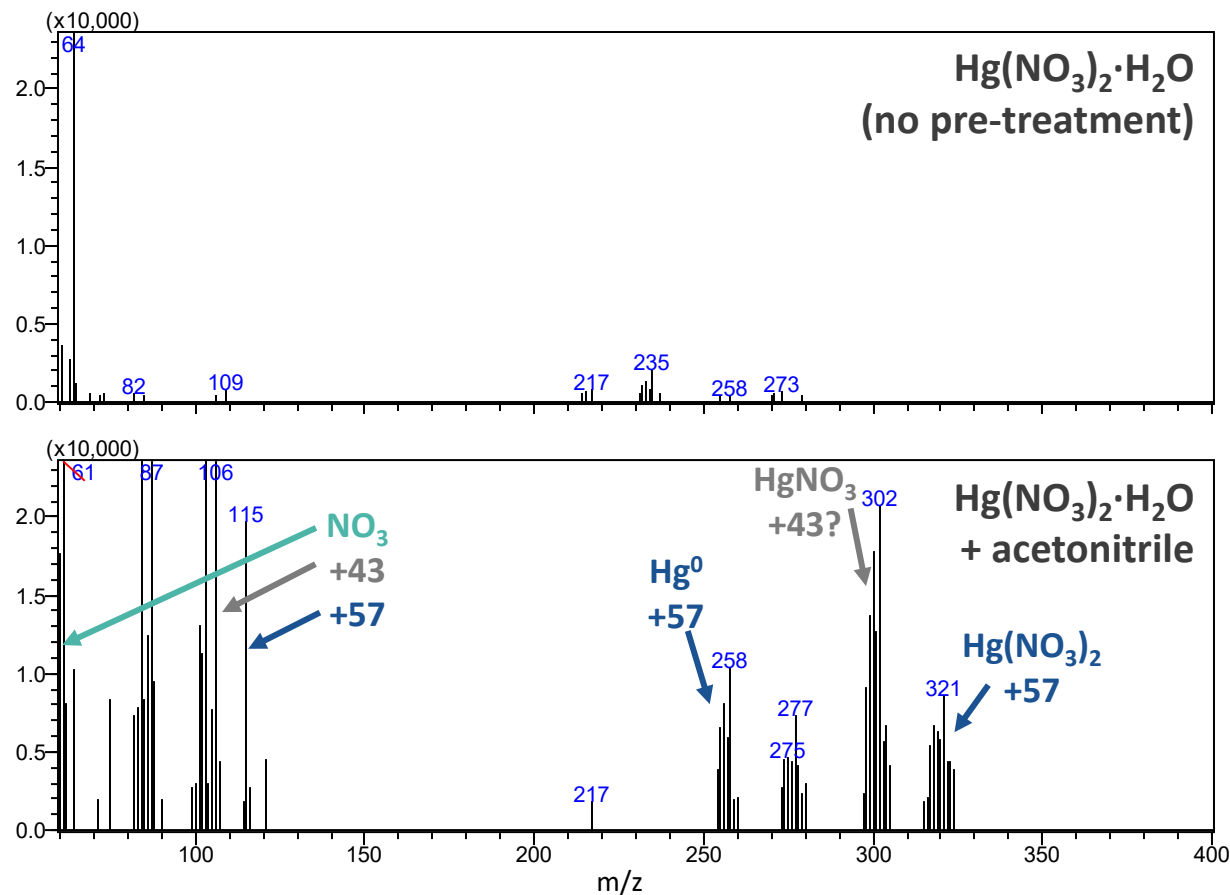

Next Steps

- Identify mechanism for $\text{Hg}(\text{NO}_3)_2$ + acetonitrile results
 - May be applicable to other Hg^{II} compounds
- Optimize MS settings for multiple Hg^{II} compounds
 - Test additional reagent gases (SF_6)
 - Add GC and cryo-trapping components back to the system
- Pursue atmospheric pressure chemical ionization mass spectrometry methods (similar to Mao & Khalizov 2021 ID-CIMS)



Acknowledgements

Support

- U.S. National Science Foundation
- University of Nevada, Reno Faculty Travel Award

Personnel

- Tyler Elgiar
- Research Technician and undergraduate research assistants in the Gustin lab



Awards: 2043042, 2044537



HgBr₂ + Solvents

Goal is to get comparable results as the pure salt (black curve, top spectrum).

Acetone removes secondary peak, not ideal.

Methanol seems to have the least overall effect on HgBr₂.

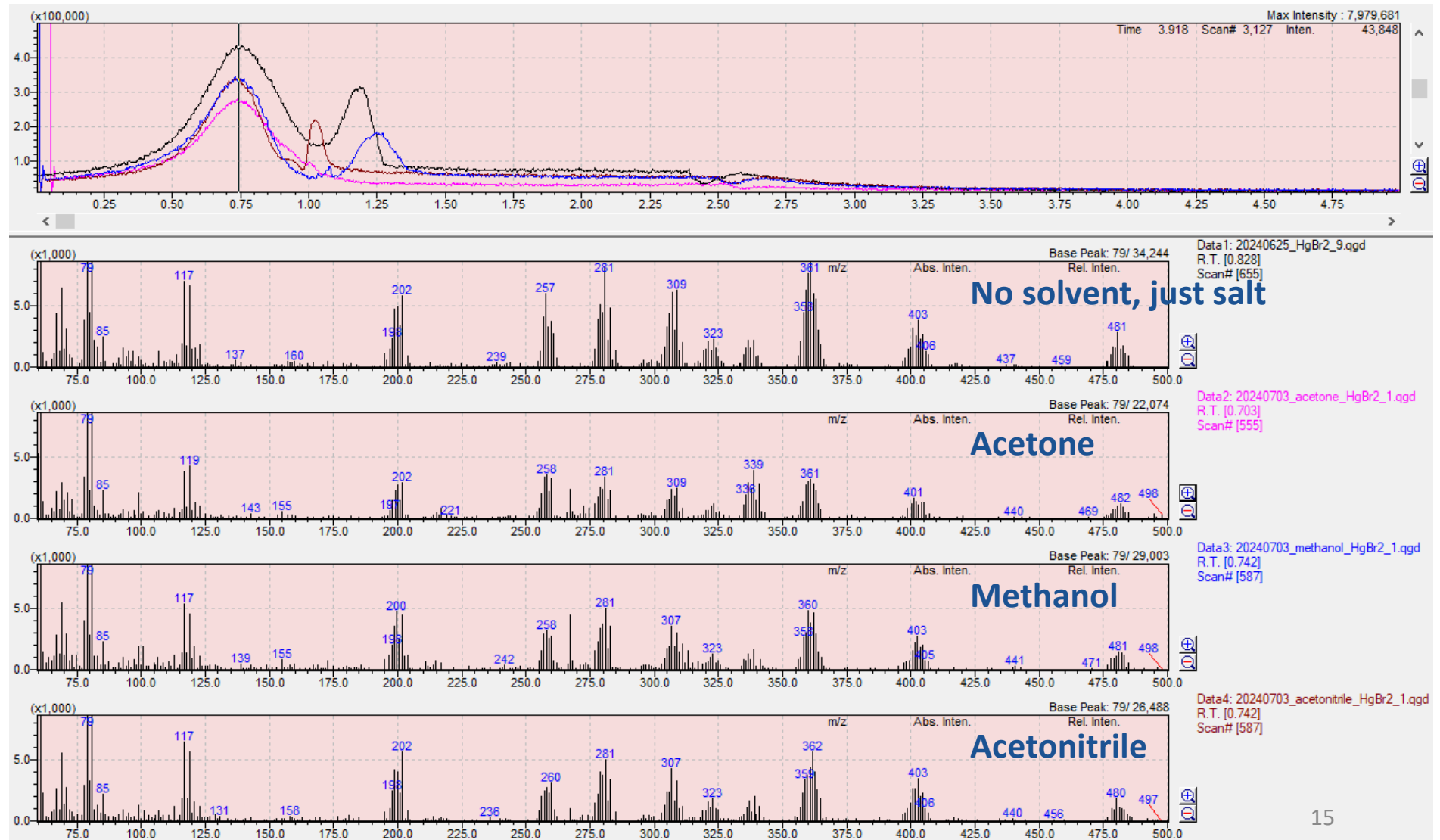

HgCl₂ + Solvents

Goal is to get comparable results as the pure salt (black curve, top spectrum).

Acetone and acetonitrile spectra are very different than the salt's.

Methanol seems to have the least overall effect on HgCl₂.

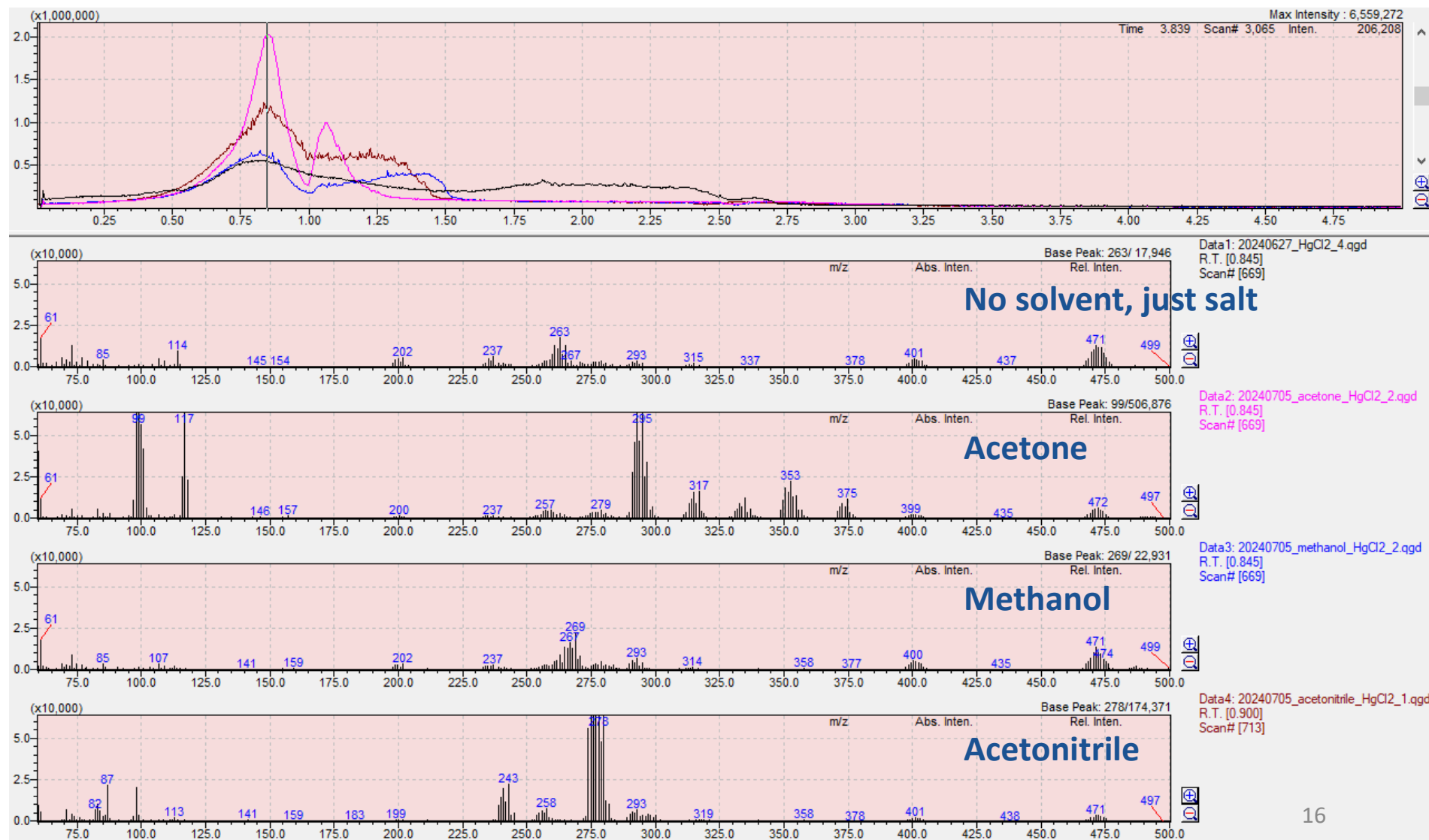

HgBr₂ + HgCl₂ Mixture

We can see a mixture of both HgBr₂ and HgCl₂ –MS spectra in the mixtures.

Next step will be to identify “qualifier” ions, similar to Deeds et al. (2015) to assess which compound(s) is present and at what proportions.

