



ICMGP 2024

CAPE TOWN • SOUTH AFRICA • 21 - 26 JULY

David Amouroux, Elaheh Lotfi-Kalahroodi, Mickael Le Behec,
Sylvain Bérail, Emmanuel Tessier, Thierry Pigot



Re-assessment of monomethylmercury
photodemethylation pathways in natural
waters using mercury stable isotopes



MMHg photochemical demethylation: odd-MIF isotopic fractionation

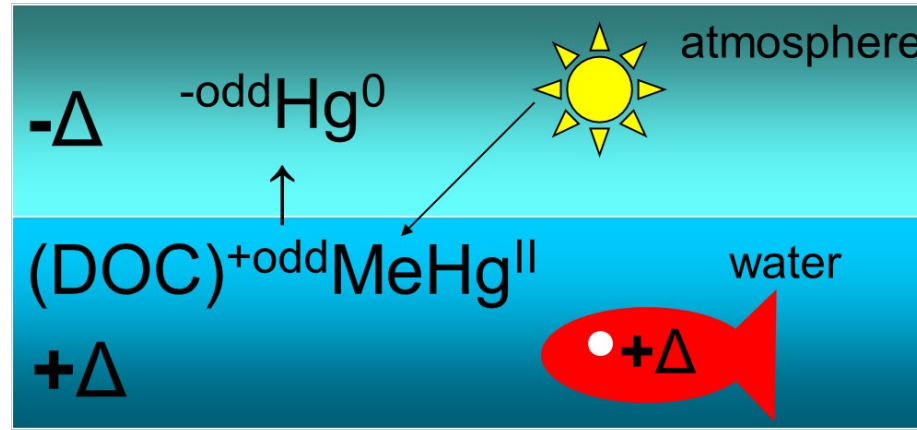
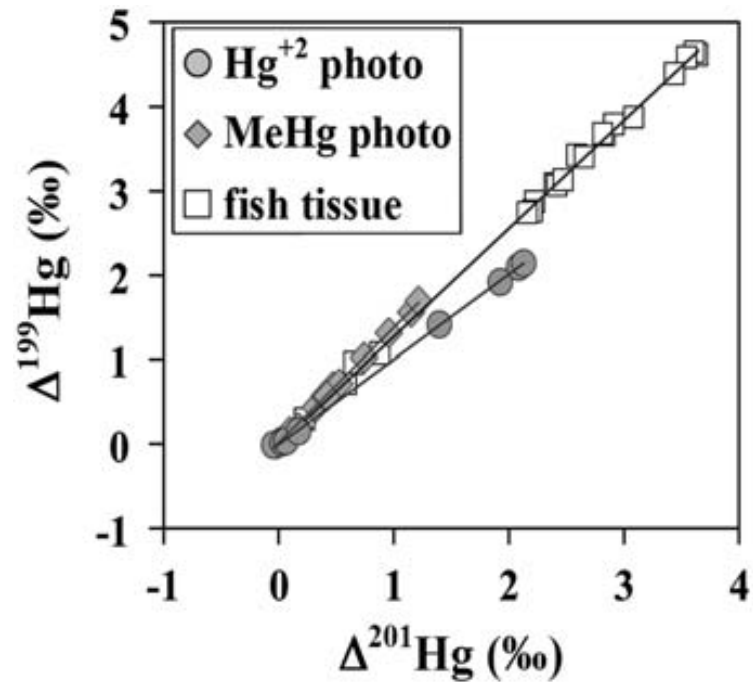

Bergquist & Blum, 2007

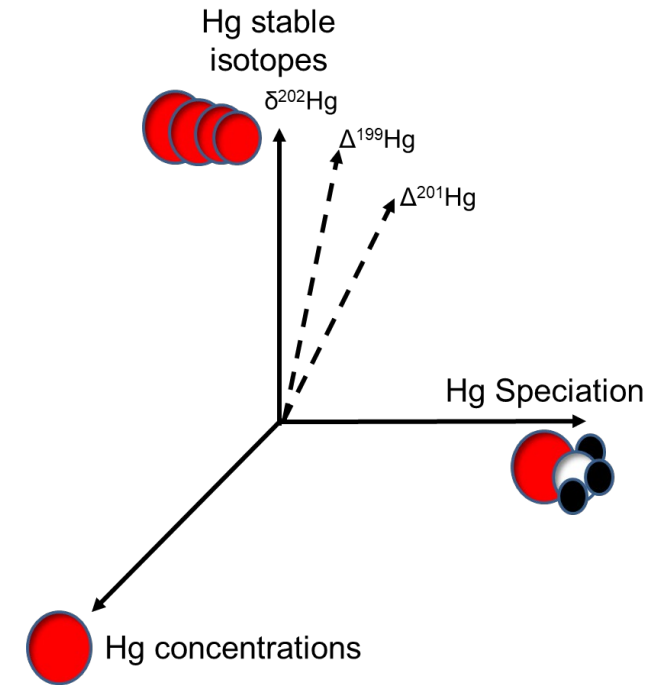

- $\Delta^{199}\text{Hg}/\Delta^{201}\text{Hg} = 1.36$ introduced and adopted as **photodemethylation** processes signature²
- **Odd-MIF magnitude** related to incident **radiation energy**: Mainly **UVB (280-320nm)** responsible for odd-MIF, less for UVA (320-400nm)¹
- Experiments conducted under **oxic** condition & **continuous purging** solution under **natural sunlight**^{1,2}
- **In situ experimental assessment** in different lakes from Bolivian Altiplano with fishes³

¹ Rose et al 2015 .²Bergquist & Blum, 2007; Blum et al 2014. ³Bouchet et al 2022.



MMHg photochemical demethylation: odd-MIF isotopic fractionation

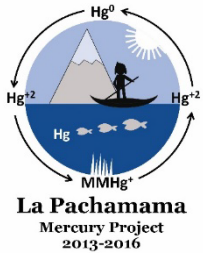

Altiplano lakes (Bolivia) Titicaca & Uru Uru

In situ photochemical
experiment assessment

*Relation between
water and fish isotopic
MIF « signature »*

$\Delta^{199}\text{Hg}$ vs $\Delta^{201}\text{Hg}$ for MMHg recorded in fish from each lake superimposed on the regression lines obtained from the incubation experiments.

Bouchet et al., ES&T 2022

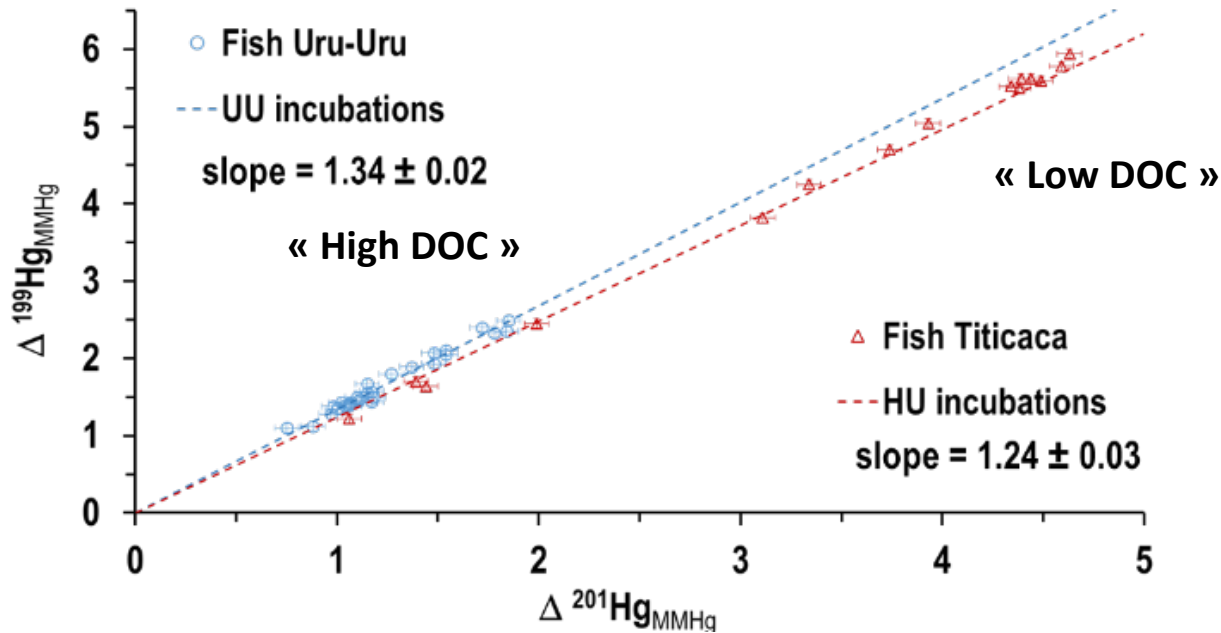
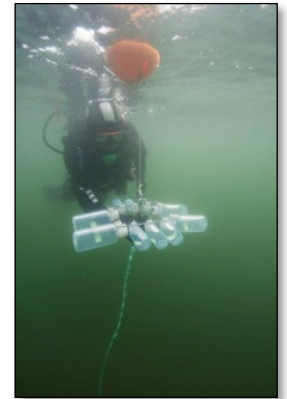
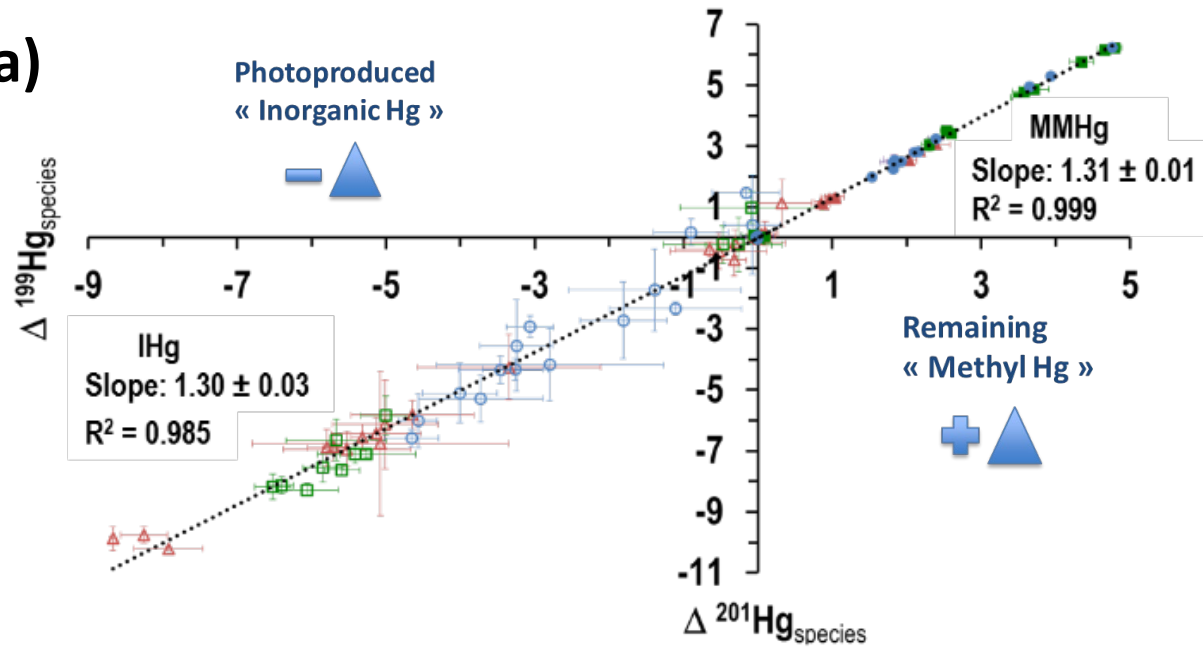

Titicaca orestias
(Orestias cuvieri)



Odd-MIF

Isotopic « signature » of MeHg sources in the environment ?

MeHg photodemethylation Hg²⁺ photoreduction

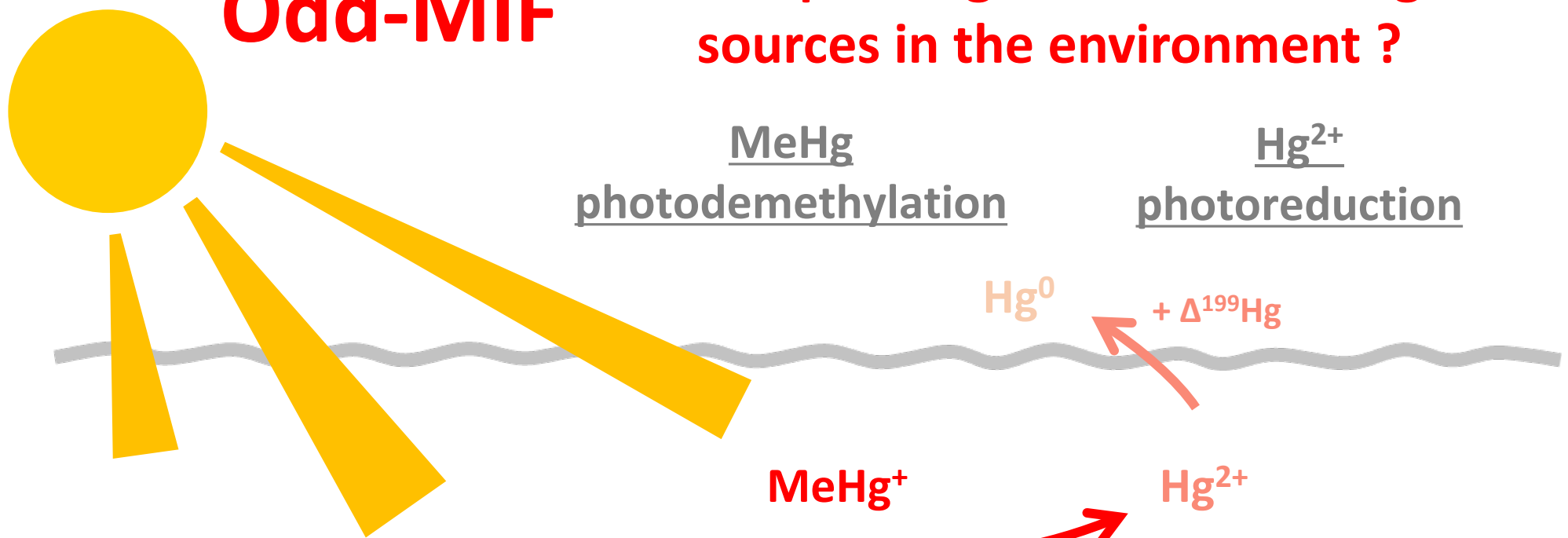

MeHg MIF aquatic organisms =
MIF MeHg before its incorporation into
food web

Zheng and Hintelmann, 2009
 Bergquist and Blum, 2007
 Perrot et al., 2012



Back to the lab !

Evaluate the contribution of various physico-chemical parameters e.g. light wavelength and redox conditions to decipher photodemethylation pathways

Need for a "simple" model freshwater medium and a well controlled experimental setup

- How the experimental setup can influence the photodemethylation rate and Hg isotopic fractionation extent ?
- How O₂ content and UV light spectral distribution affect the odd-MIF signature?
- How lab experiments can be useful for environmental isotopic data evaluation and source tracking ?



I. Continuous- irradiation purging: *Cont.*

$Hg_{(g)}$ trapped continuously & no Hg deposition into solution

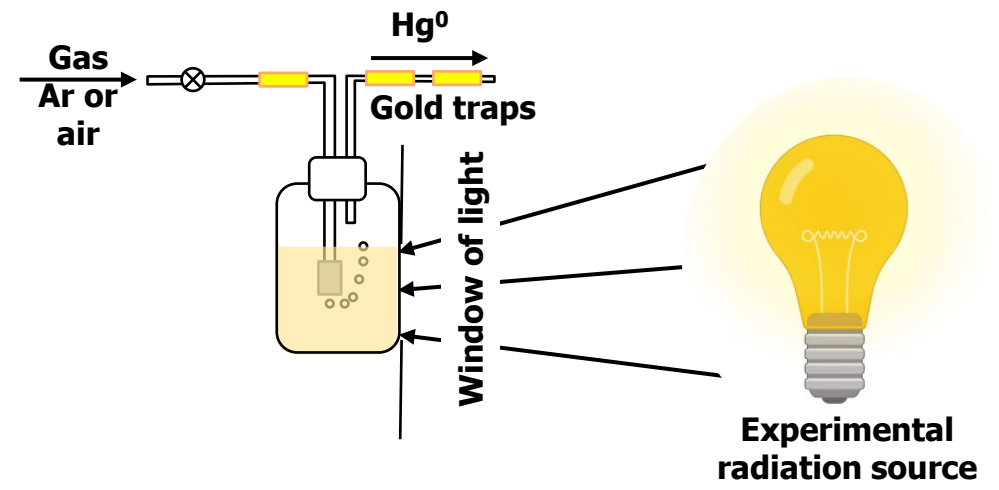

II. Post-irradiation purging: *Post*

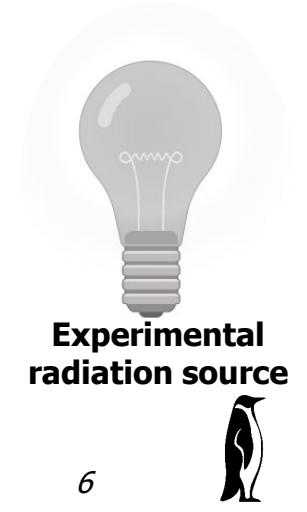
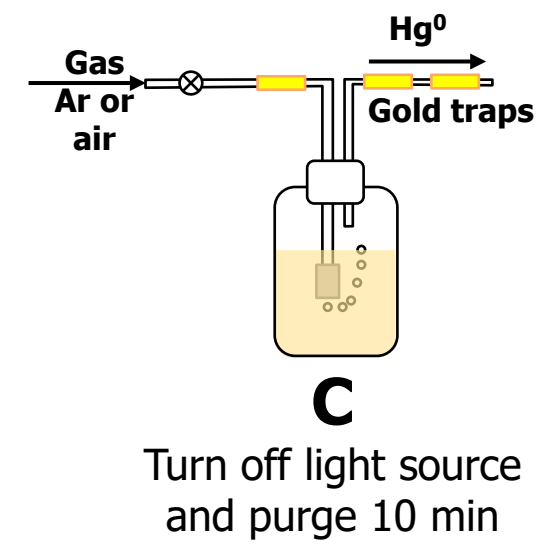
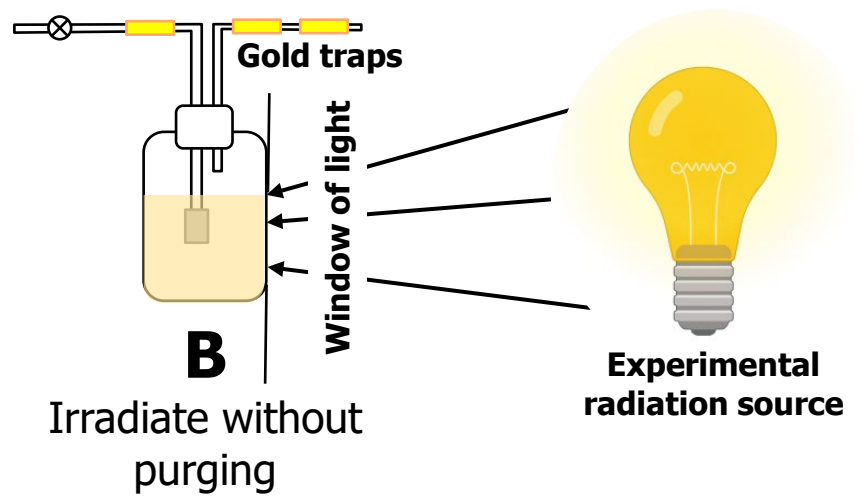
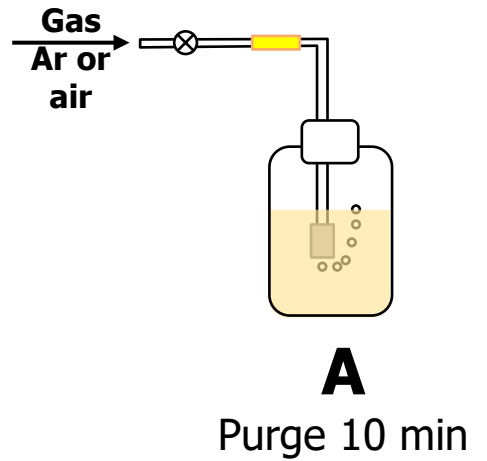

Methodological approach

- ✓ [MMHg]= 50 ppb
- ✓ Dissolved fulvic acid (SRFA*) IHSS (Filtered at 0.2 μm)
- ✓ [DOC]_{fulvic acid}= 6 ppm
- ✓ $V_{\text{PFA}}=35 \text{ mL}$
- ✓ Head space = 15 mL
- ✓ Equilibration overnight



pH=6.5-7

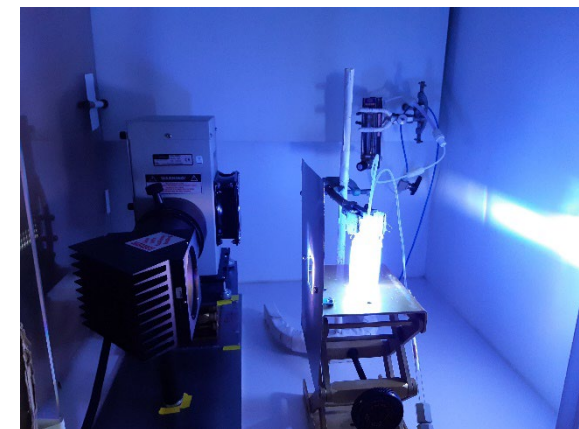

**Strong radiations in UV domain
(280-400 nm):**

No short UVB: $\lambda=305-800 \text{ nm}$

+ short UVB: $\lambda=280-800 \text{ nm}$

Under anoxic and oxic conditions:

- ✓ air purging
- ✓ Ar purging

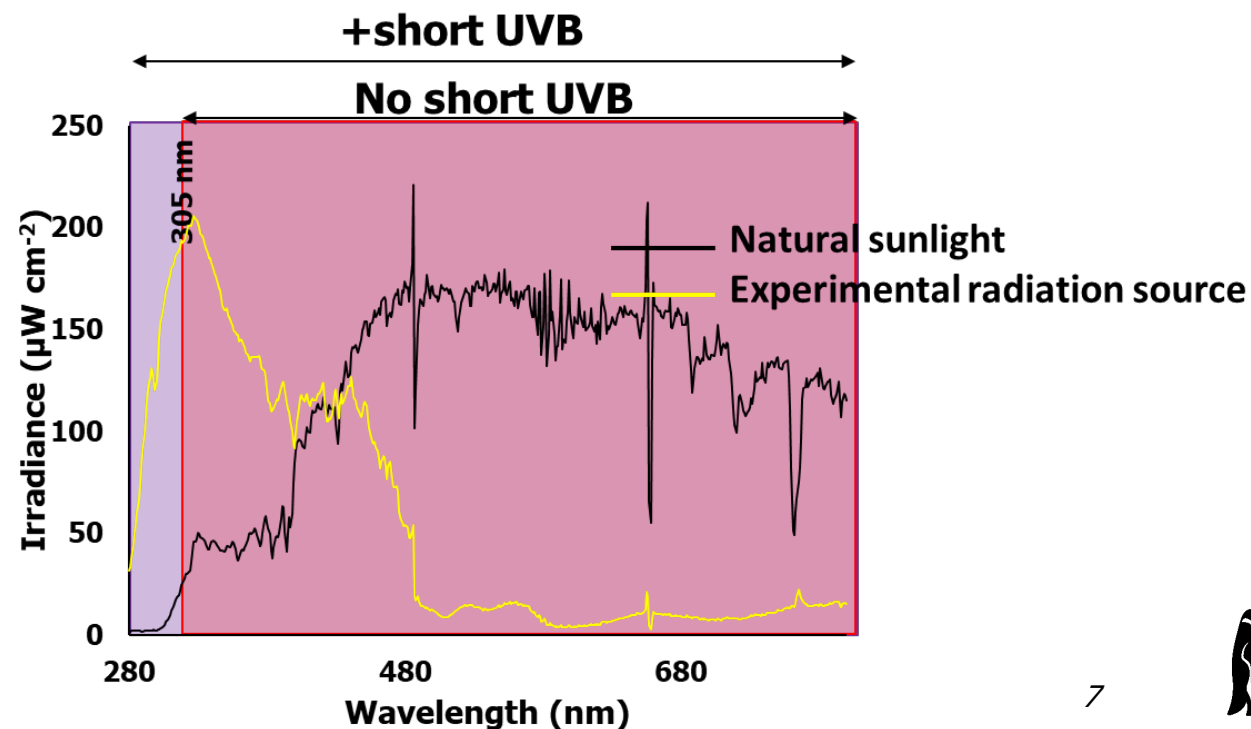

Results & Discussion: Experimental kinetics & Hg speciation

Photochemical pathways as controlled by experimental conditions: first conclusions

Elaheh Lotfi-Kalahroodi et al., Chemosphere 2023

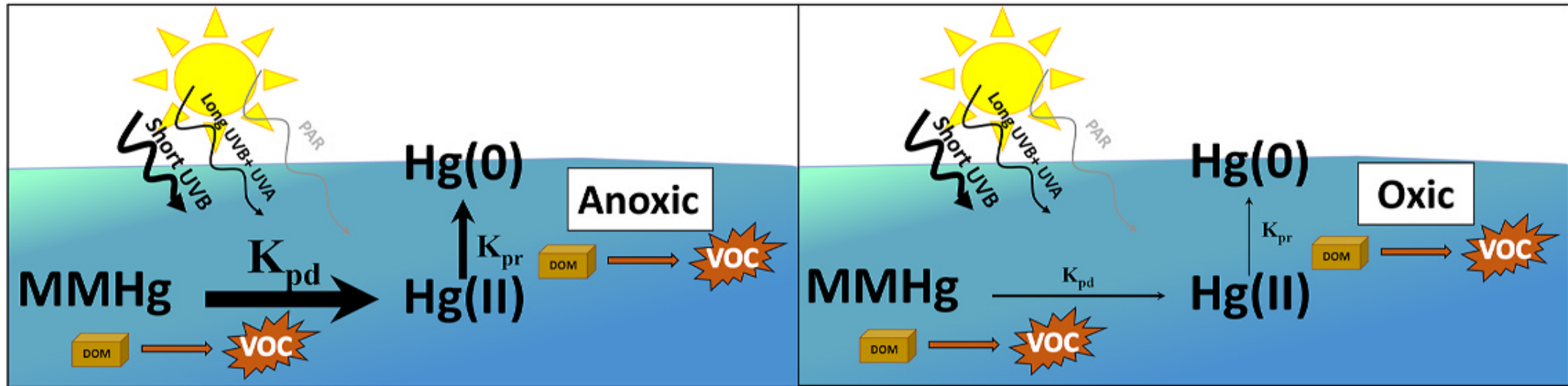

- MMHg photodecomposition follows a first step of MMHg photodemethylation to iHg(II) and second step of photoreduction of iHg(II) to Hg(0).
- Dissolved O_2 is an inhibitor for the photodemethylation process (ROS generation, DOM oxidation).
- Low molecular weight volatile organic compounds enhance the photoreactivity.
- Photoreduction under natural sunlight is more dependent on UV compared to photodemethylation. ⁸



Results & Discussion: Experimental kinetics & Hg stable isotopes

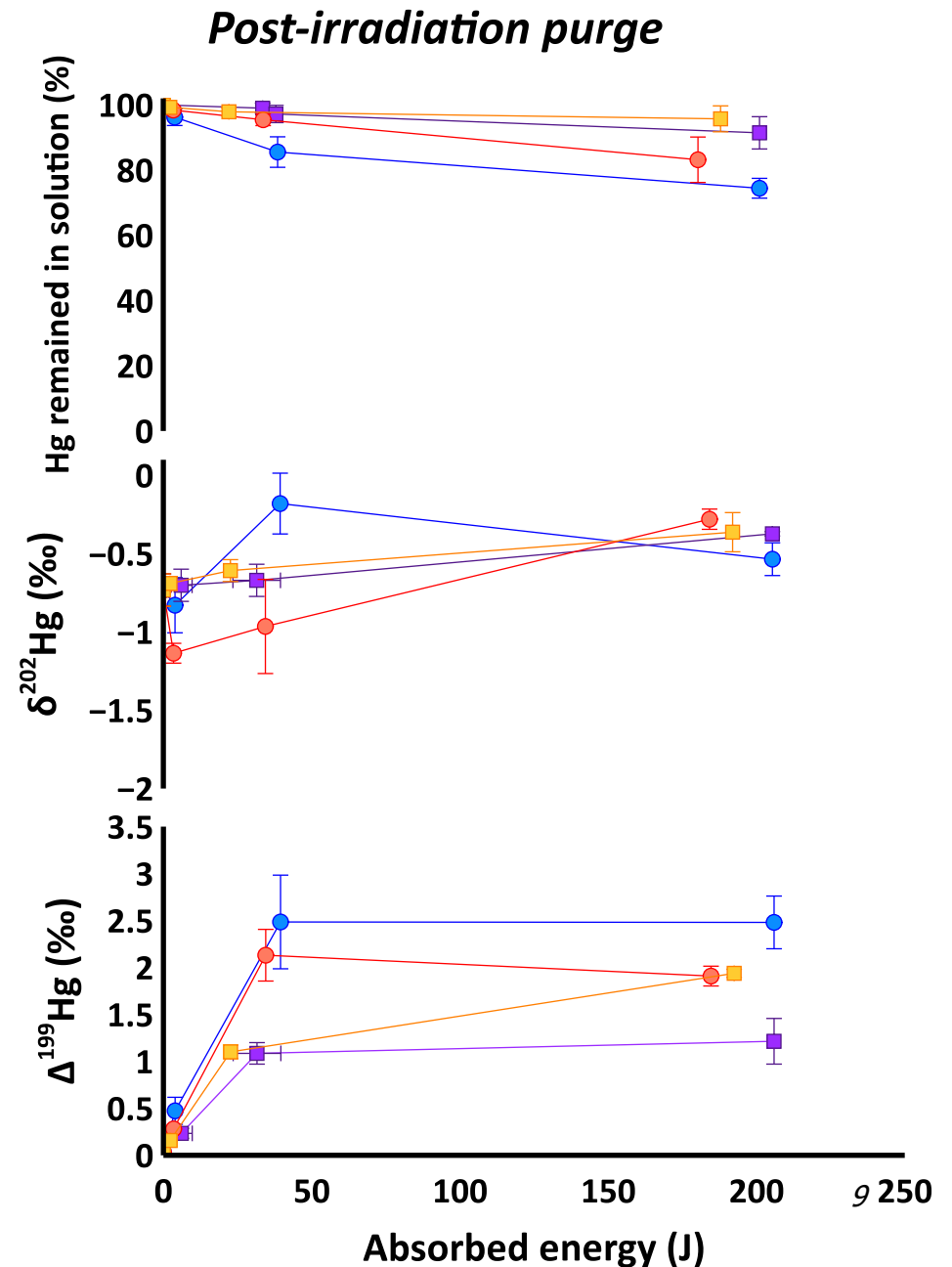
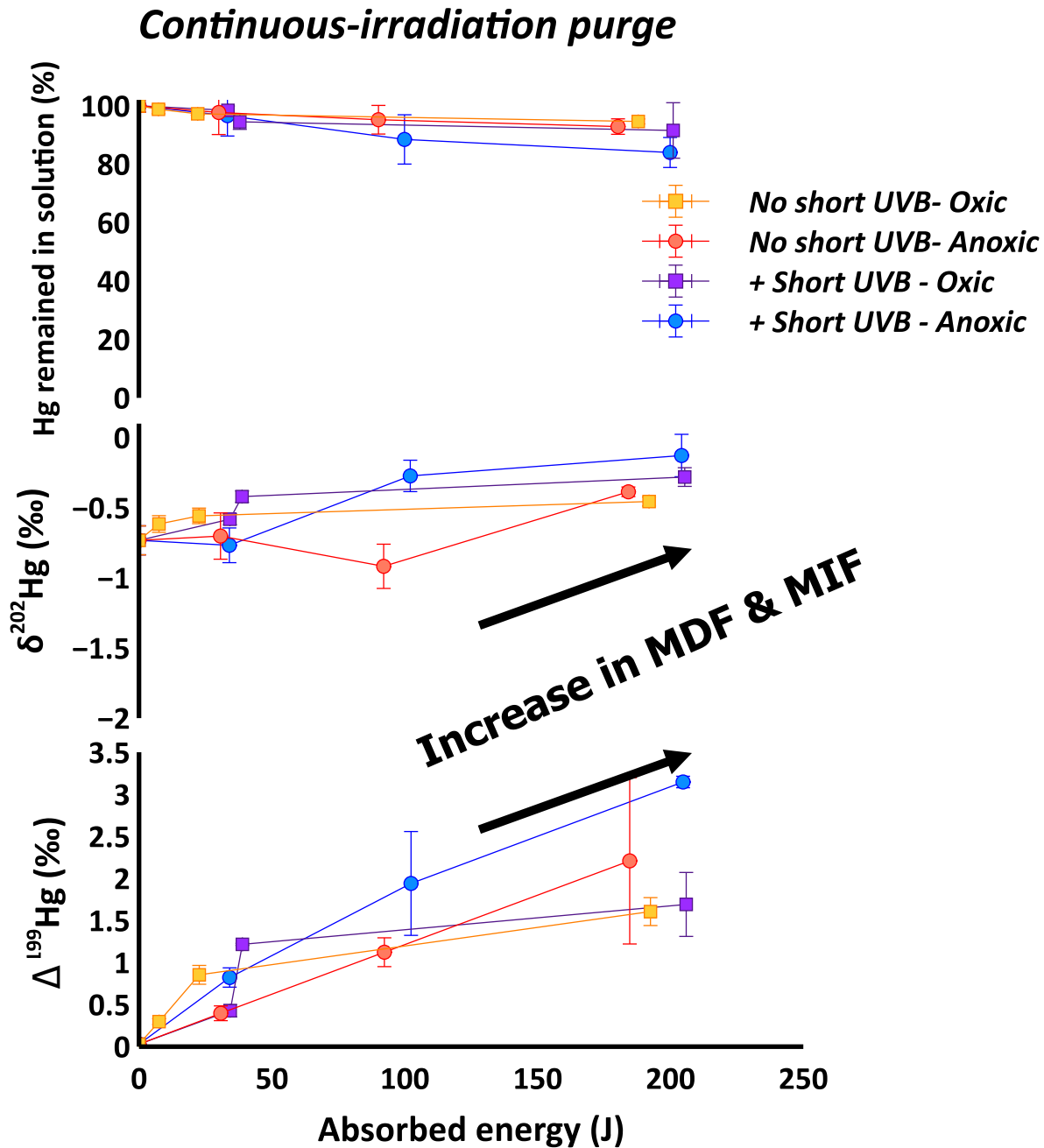

Results & Discussion: Odd MIF relationship

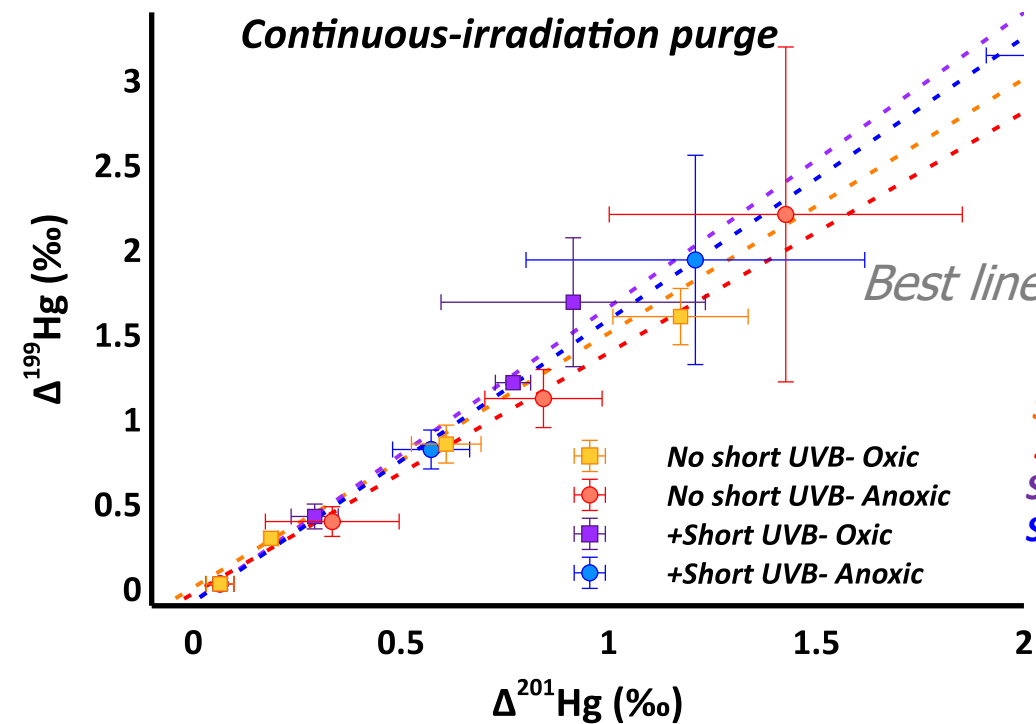

Best linear fit determined by York regression using OriginLab 2020:

Slope= 1.41 ± 0.08 , $R_{\text{pearson}} = 1.00$
 Slope= 1.41 ± 0.04 , $R_{\text{pearson}} = 0.99$
 Slope= 1.75 ± 0.08 , $R_{\text{pearson}} = 0.99$
 Slope= 1.64 ± 0.04 , $R_{\text{pearson}} = 0.99$

Significantly higher $\Delta^{199}\text{Hg}/\Delta^{201}\text{Hg}$ than adopted value ≈ 1.36 for **photodemethylation** in the presence of **short UVB wavelength**

No fractionation of even isotopes
 \Rightarrow **Magnetic Isotope Effect (MIE)***

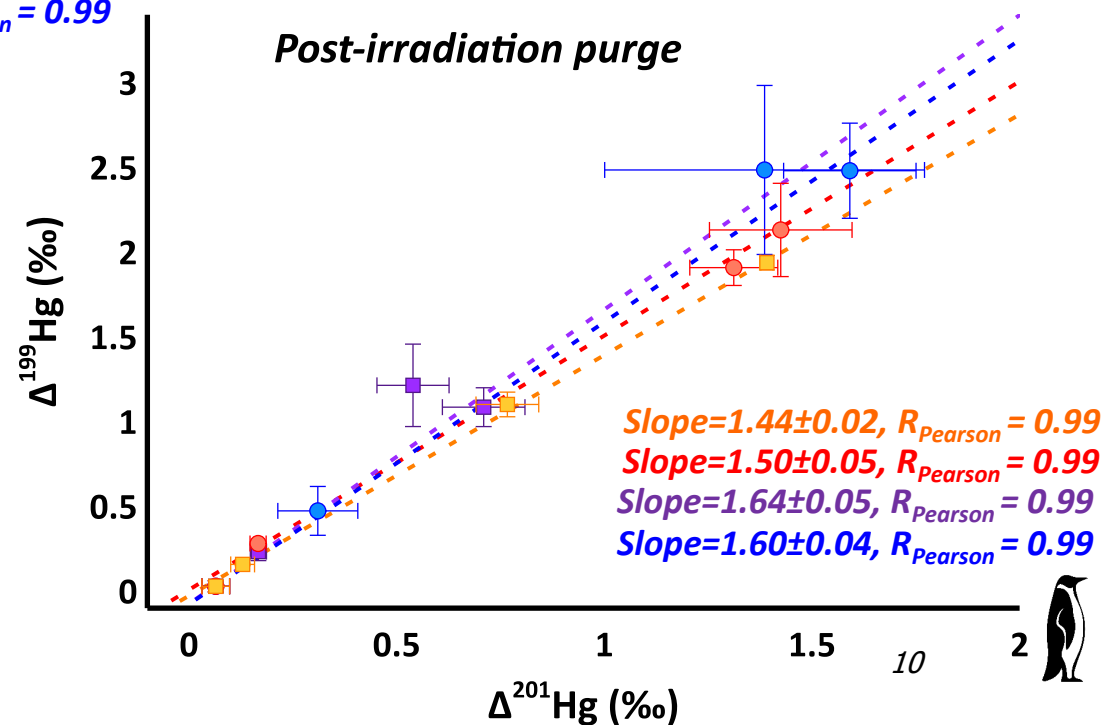

*Schauble et al. 2007

Results & Discussion: Odd MIF relationship

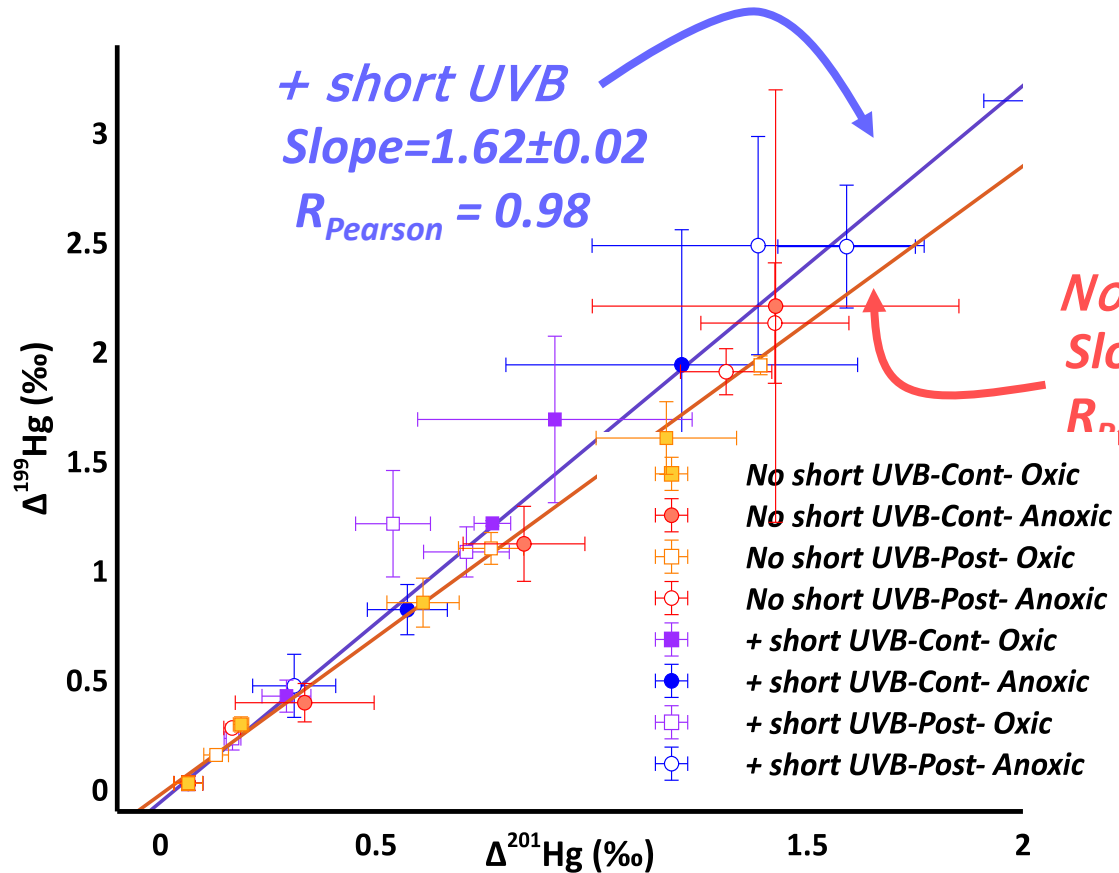

Photodemethylation odd-MIF isotopic "signature" $\Delta^{199}\text{Hg}/\Delta^{201}\text{Hg}$ is affected by irradiation wavelength

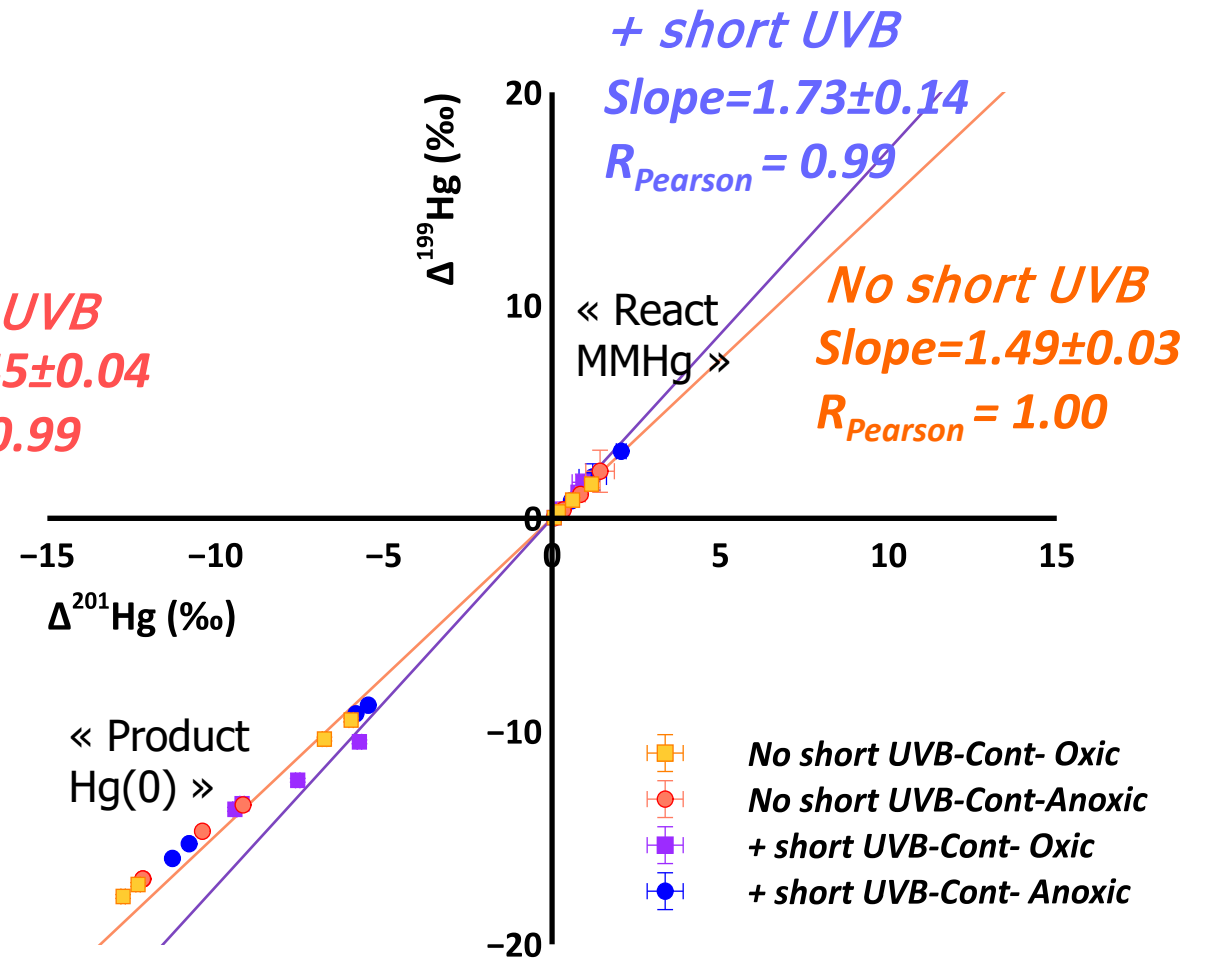

Results confirmed by the relationship between reactant and product isotopic odd-MIF



Results & Discussion: enrichment factors vs rate constants

$$(10^{-3} \epsilon_{\Delta^{199}\text{Hg}}) \ln f = \ln \frac{10^{-3} \Delta^{199}\text{Hg}_t + 1}{10^{-3} \Delta^{199}\text{Hg}_{\text{initial}} + 1}$$

Continuous-irradiation purge

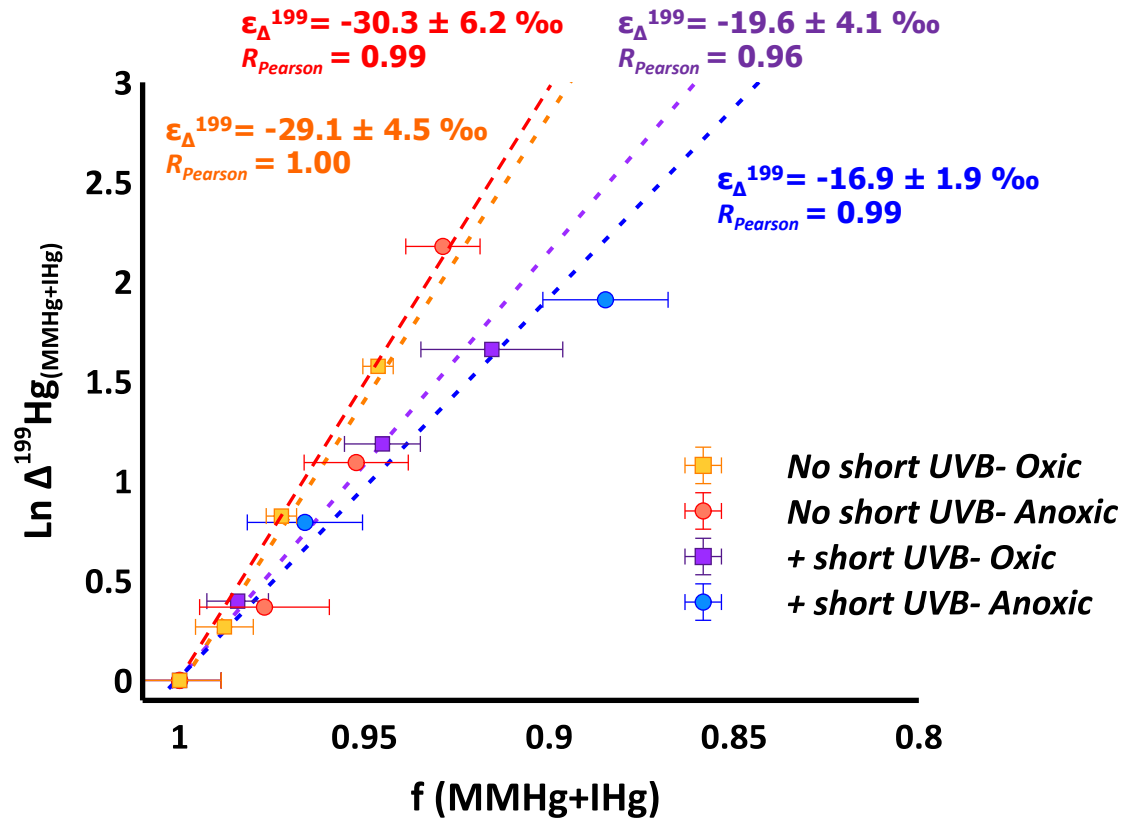

Modification in enrichment factor by variation in environmental parameters: wavelength light, purging mode meaning *photodemethylation* and *photoreduction kinetics*

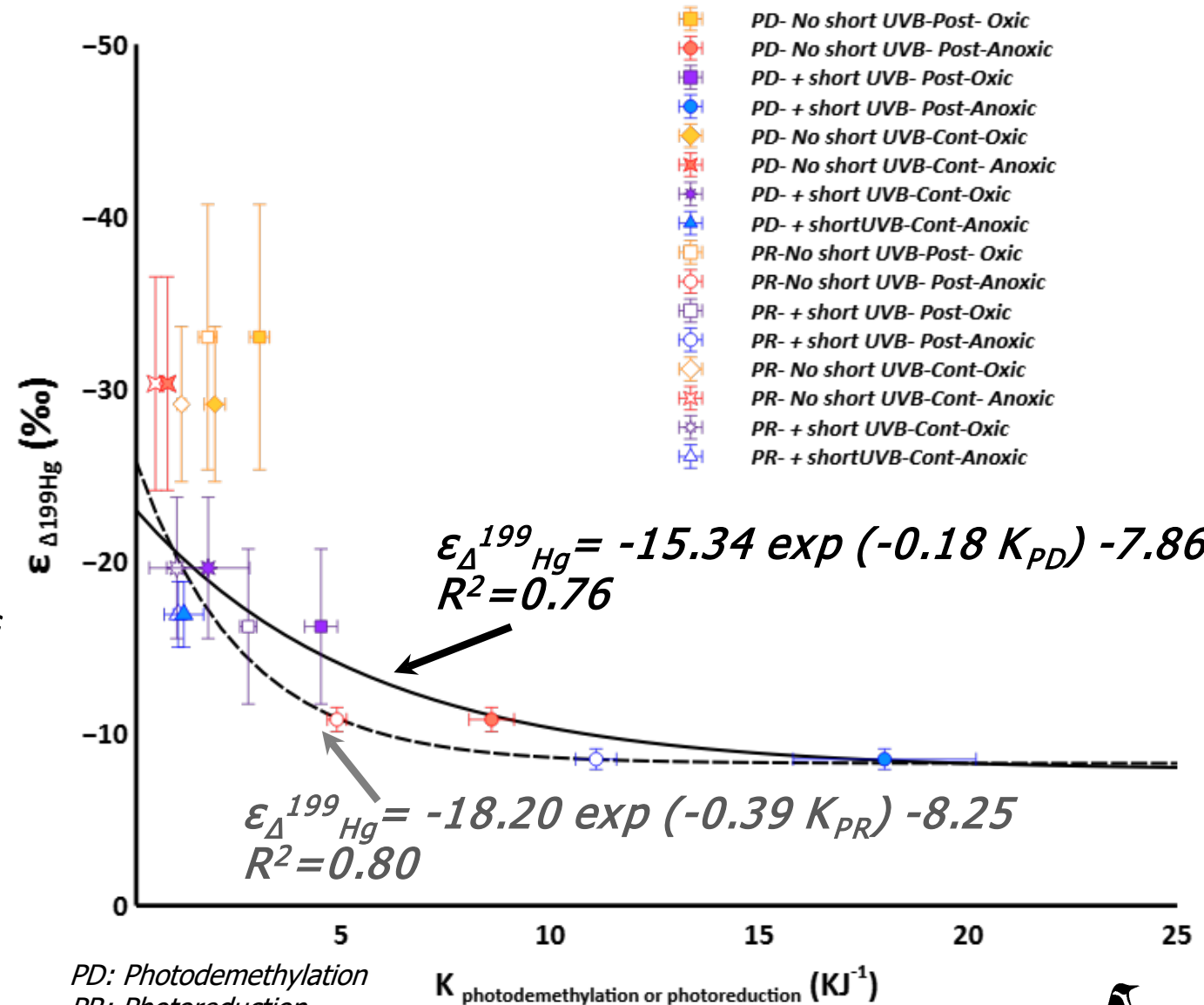

PD: Photodemethylation
PR: Photoreduction

$K_{\text{photodemethylation or photoreduction}} (\text{KJ}^{-1})$



Take home messages

- **Odd isotopes Enrichment factor of photodemethylation depends on reaction kinetics which are highly controlled by redox conditions and short UVB spectral distribution.**
- **Oxygen inhibits and modifies the photodemethylation pathways e.g. ROS production & DOM photobleaching increase odd isotopes enrichment factor.**
- **Photodemethylation odd-MIF signature (Magnetic Isotopic Effect) $\Delta^{199}\text{Hg}/\Delta^{201}\text{Hg}$ vary significantly in the presence of short UVB (280-305 nm).**
- **Our results combined with previous in situ experiments and biota Hg isotopic composition of MMHg suggest that short UVB are not major drivers for photodemethylation in natural aquatic systems.**

